EECE488: Analog CMOS Integrated Circuit Design

Set 7

Opamp Design

**References: “Analog Integrated Circuit Design” by D. Johns and K. Martin
and “Design of Analog CMOS Integrated Circuits” by B. Razavi**

All figures in this set of slides are taken from the above books

Shahriar Mirabbasi
Department of Electrical and Computer Engineering
University of British Columbia
shahriar@ece.ubc.ca

General Considerations

- Gain
- Small-signal bandwidth
- Large-signal performance
- Output swing
- Input common-mode range
- Linearity
- Noise/offset
- Supply rejection

One-Stage Op Amps

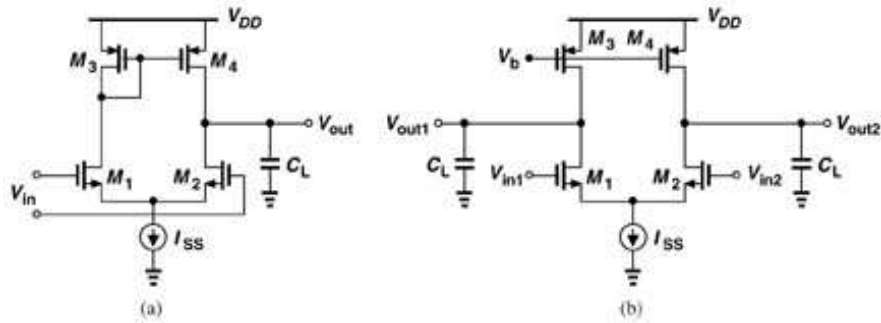

SM

EECE488 Set 7 - Opamp Design

3

One-Stage Op Amp in Unity Gain Configuration

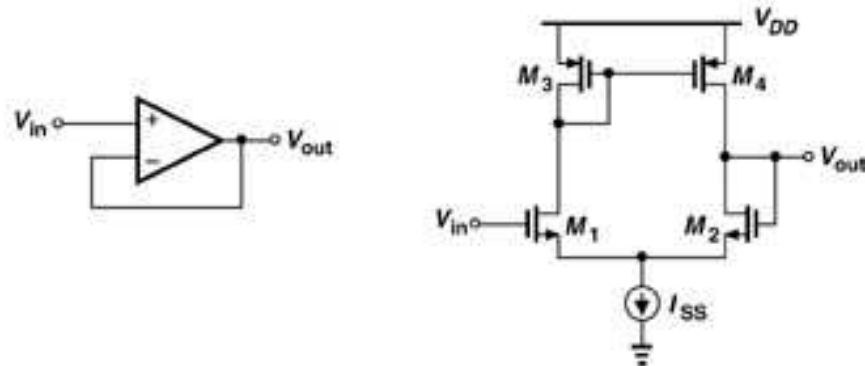

SM

EECE488 Set 7 - Opamp Design

4

Cascode Op Amps

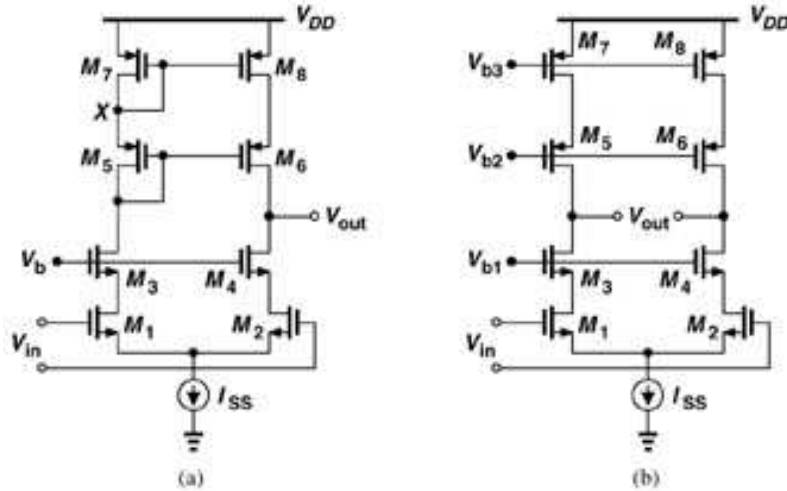

SM

EECE488 Set 7 - Opamp Design

5

Unity Gain One Stage Cascode

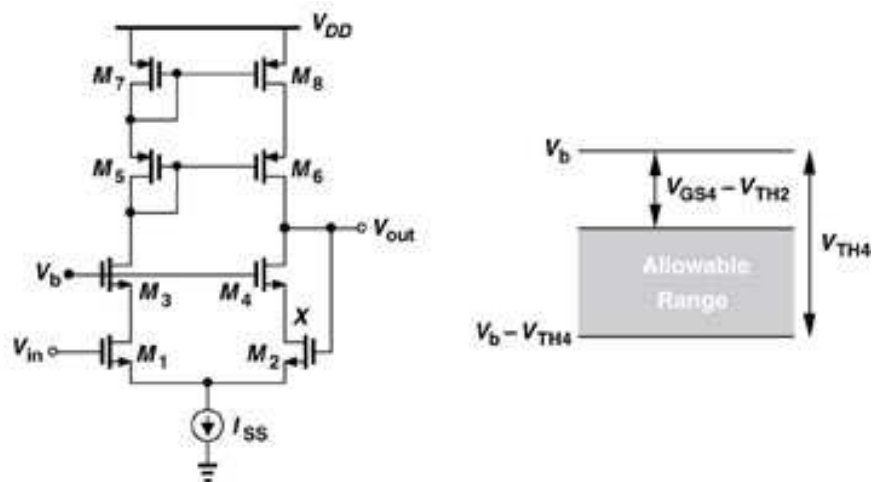

SM

EECE488 Set 7 - Opamp Design

6

Folded Cascode Op Amps

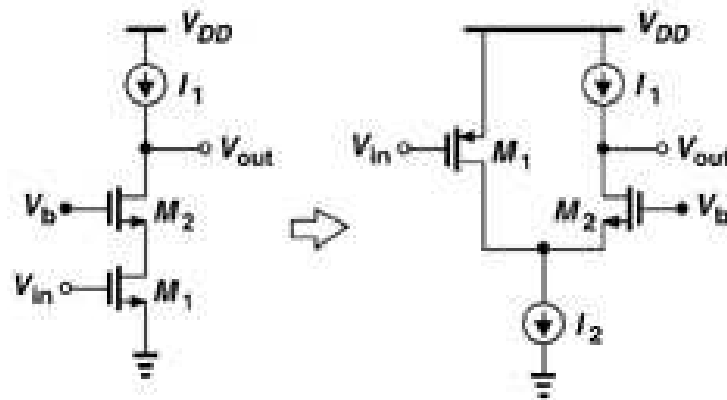

SM

EECE488 Set 7 - Opamp Design

7

Folded Cascode Stages

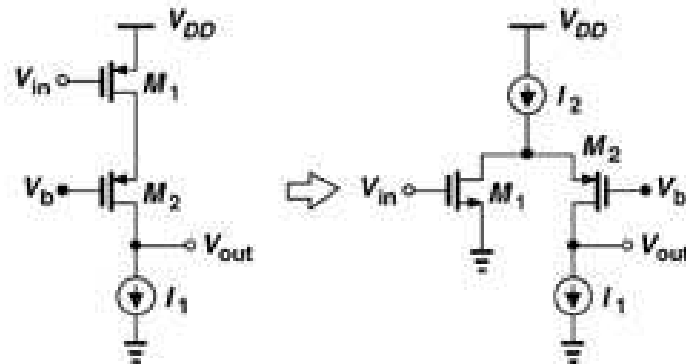

SM

EECE488 Set 7 - Opamp Design

8

Folded Cascode (cont.)

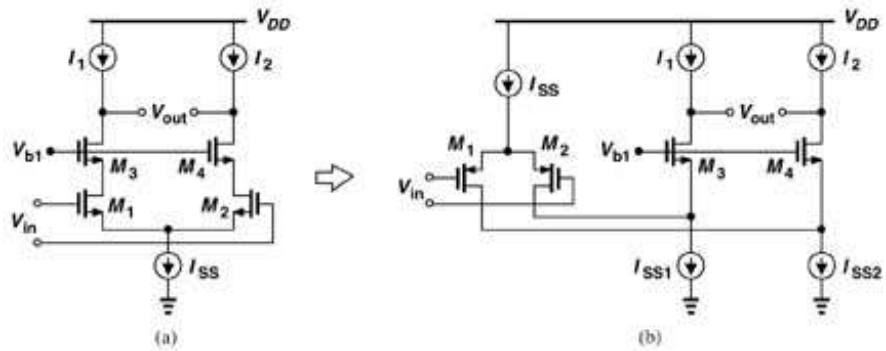

SM

EECE488 Set 7 - Opamp Design

9

Folded Cascode (cont.)

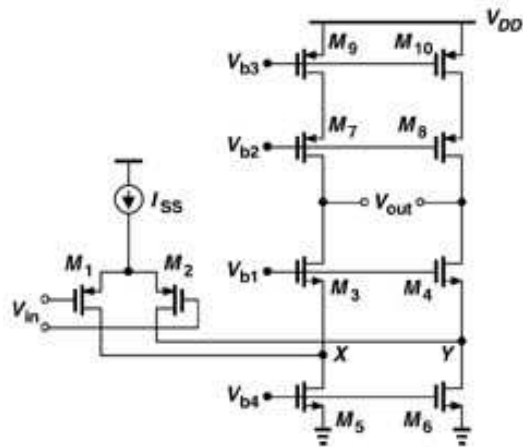

$$|A_v| \approx g_{m1} \{ [(g_{m3} + g_{mb3})r_{o3}(r_{o1} \parallel r_{o5})] \parallel [(g_{m7} + g_{mb7})r_{o7}r_{o9}] \}$$

SM

EECE488 Set 7 - Opamp Design

10

Telescopic versus Folded Cascode

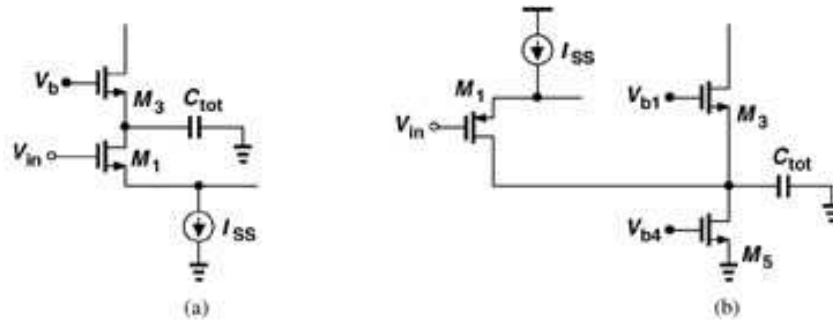

SM

EECE488 Set 7 - Opamp Design

11

Example Folded-Cascode Op Amp

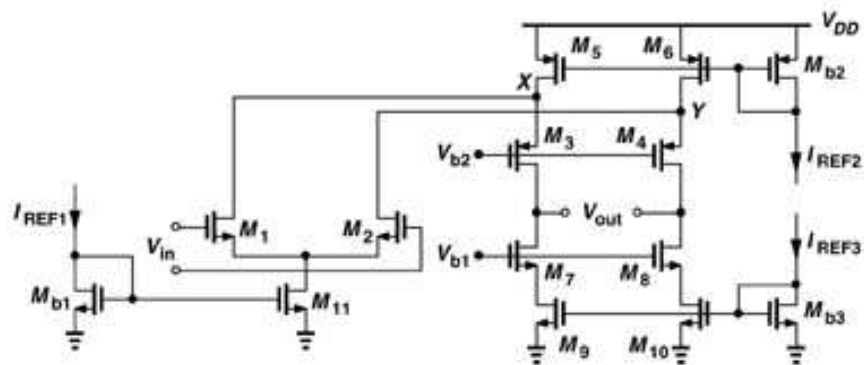

SM

EECE488 Set 7 - Opamp Design

12

Single-Ended Output Cascode Op Amps

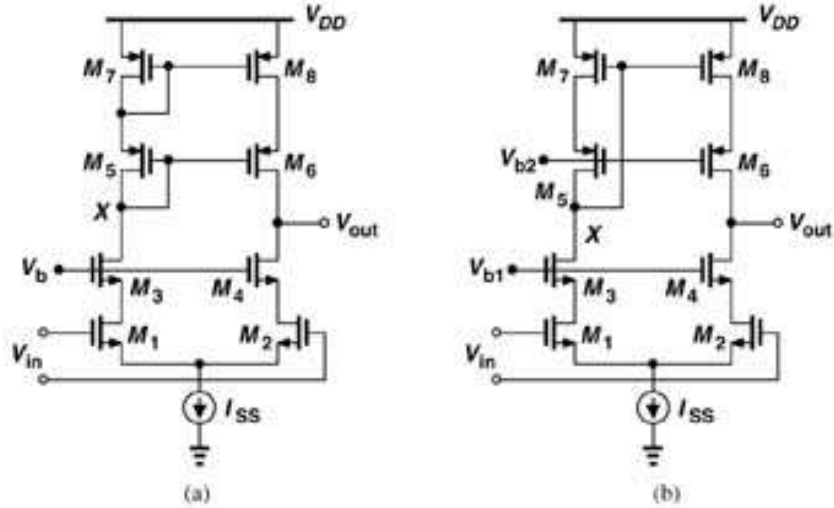

SM

EECE488 Set 7 - Opamp Design

13

Triple Cascode

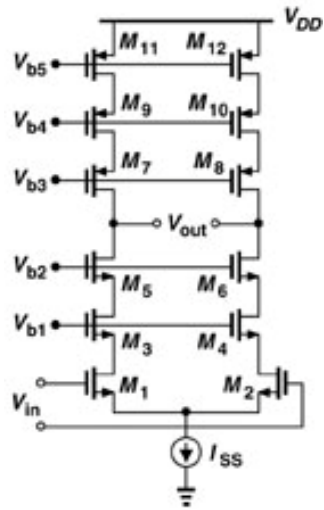

$$A_v \text{ app. } (g_m r_o)^3 / 2$$

Limited Output Swing

Complex biasing

SM

EECE488 Set 7 - Opamp Design

14

Output Impedance Enhancement

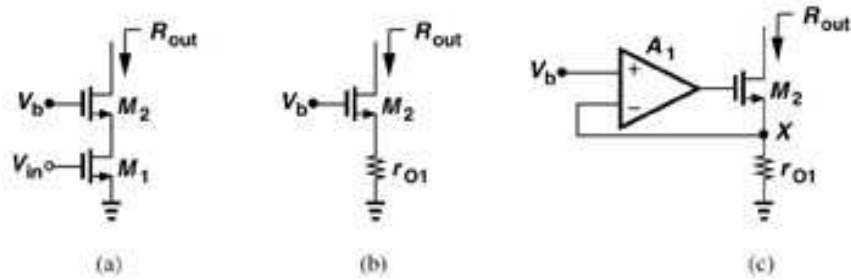

$$R_{out} = A_1 g_{m2} r_{o2} r_{o1}$$

SM

EECE488 Set 7 - Opamp Design

15

Gain Boosting in Cascode Stage

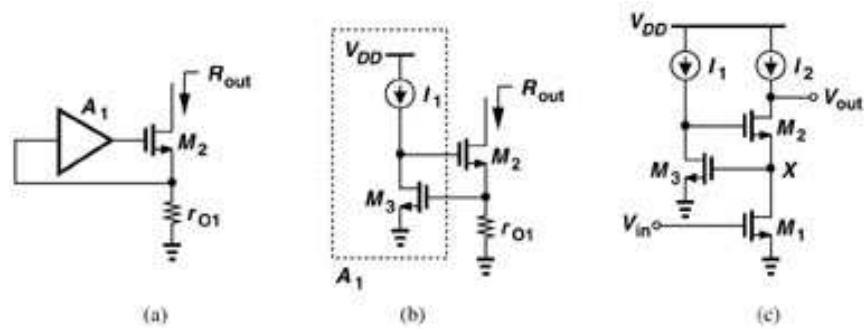

SM

EECE488 Set 7 - Opamp Design

16

Differential Gain Boosting

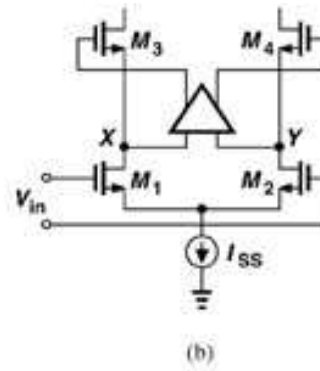
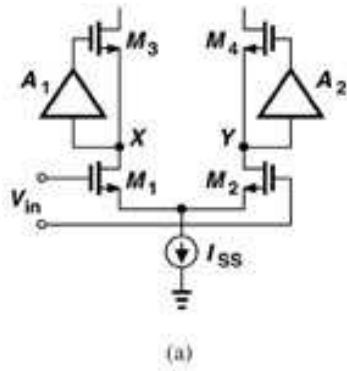

Differential Gain Boosting

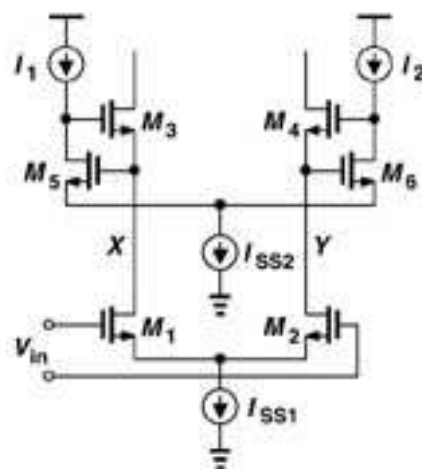

Differential Gain Boosting

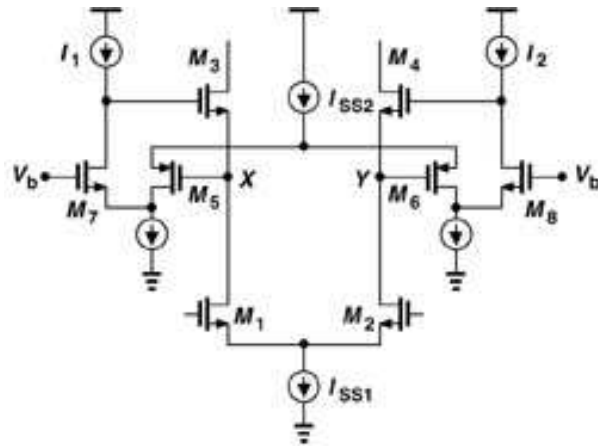

SM

EECE488 Set 7 - Opamp Design

19

Two-Stage Op Amps

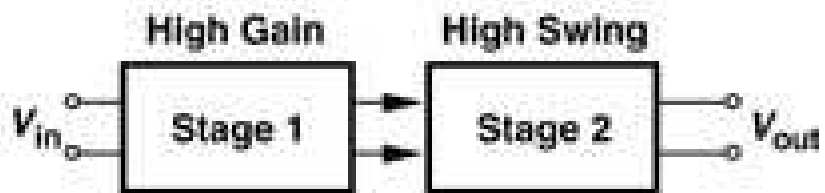

SM

EECE488 Set 7 - Opamp Design

20

Single-Ended Output Two-Stage Op Amp

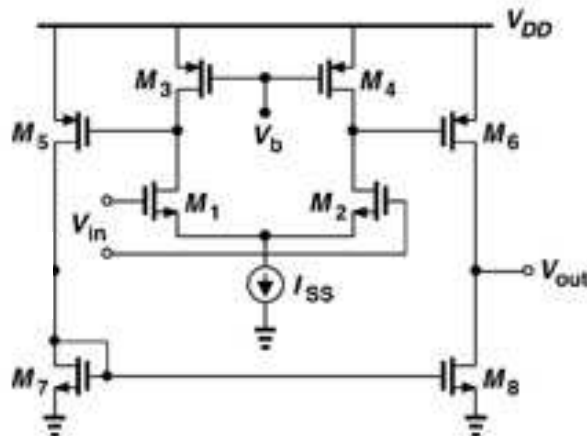

SM

EECE488 Set 7 - Opamp Design

21

Two-Stage CMOS Opamp

- Popular opamp design approach
- A good example to review many important design concepts
- Output buffer is typically used to drive resistive loads
- For capacitive loads (typical case in CMOS) buffer is not required.

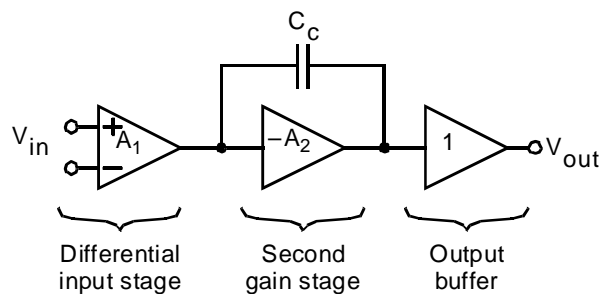

SM

EECE488 Set 7 - Opamp Design

22

Two-Stage CMOS Opamp Example

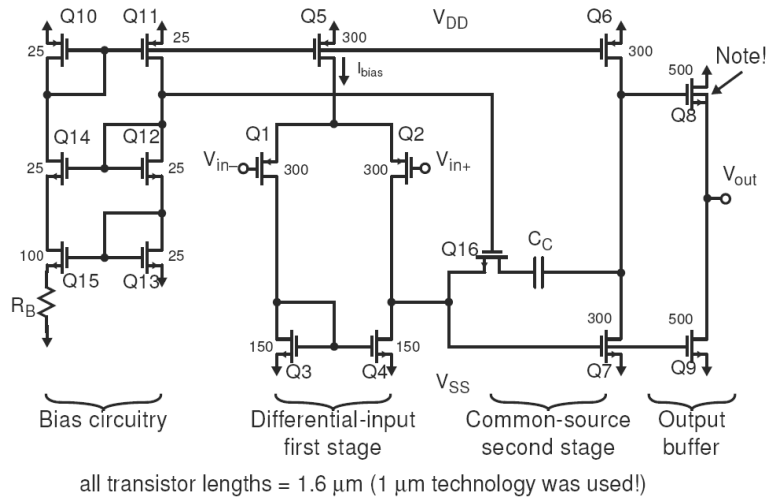

SM

EECE488 Set 7 - Opamp Design

23

Gain of the Opamp

- First Stage
Differential to single-ended

$$A_{V1} = g_{m1}(r_{O2} \parallel r_{O4})$$

$$g_{m1} = \sqrt{2\mu_p C_{ox} \left(\frac{W}{L}\right)_1 I_{D1}} = \sqrt{2\mu_p C_{ox} \left(\frac{W}{L}\right)_1 \frac{I_{bias}}{2}}$$

- Second Stage
Common-source stage

$$A_{V2} = -g_{m7}(r_{O6} \parallel r_{O7})$$

- Output buffer is not required when driving capacitive loads

SM

EECE488 Set 7 - Opamp Design

24

Gain of the Opamp

Third Stage

- Source follower

$$A_{V3} \cong \frac{g_{m8}}{g_{m8} + G_L + g_{mb8} + g_{O8} + g_{O9}}$$

- Typical gain: between 0.7 to 1
- Note: $g_o = 1/r_o$ and $G_L = 1/R_L$
- g_{mb} is body-effect conductance (is zero if source can be tied to substrate)

SM

EECE488 Set 7 - Opamp Design

25

Frequency Response

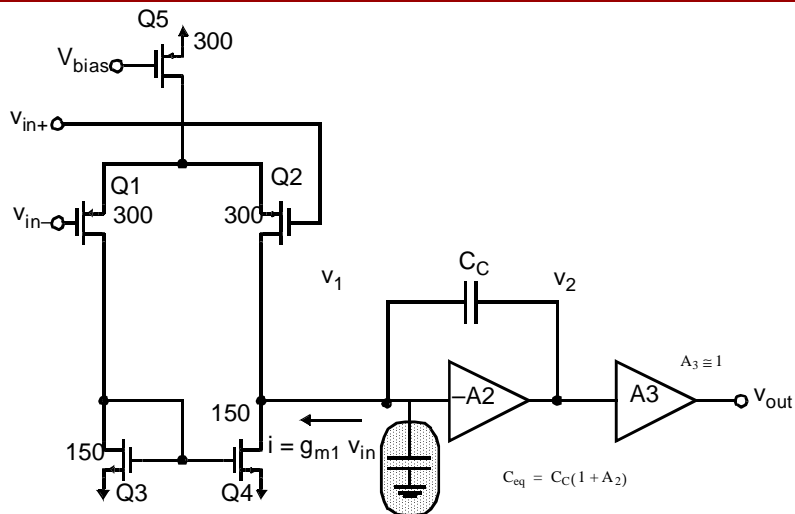

SM

EECE488 Set 7 - Opamp Design

26

Frequency Response

Simplifying assumptions:

- C_C dominates
- Ignore Q_{16} for the time being (it is used for lead compensation)

Miller effect results in

$$C_{eq} = C_C(1 + A_2) \cong C_C A_2$$

- At midband frequencies

$$Z_{eq} = r_{O2} \parallel r_{O4} \parallel 1/sC_{eq} \cong 1/(sC_C A_2)$$

$$A_1 = g_{m1} Z_{eq} = g_{m1}/(sC_C A_2)$$

SM

EECE488 Set 7 - Opamp Design

27

Frequency Response

- Overall gain (assuming $A_3 \approx 1$)

$$A_V(s) = A_2 A_1 = g_{m1}/(sC_C)$$

which results in a unity-gain frequency of

$$\omega_{ta} = g_{m1}/C_C$$

- Note: ω_{ta} is directly proportional to g_{m1} and inversely proportional to C_C .

SM

EECE488 Set 7 - Opamp Design

28

Frequency Response

- First-order model

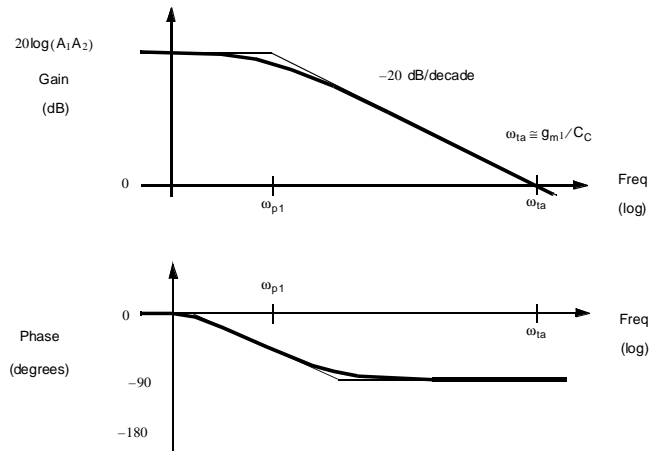

SM

EECE488 Set 7 - Opamp Design

29

Slew Rate

- Maximum rate of output change when input signal is large.

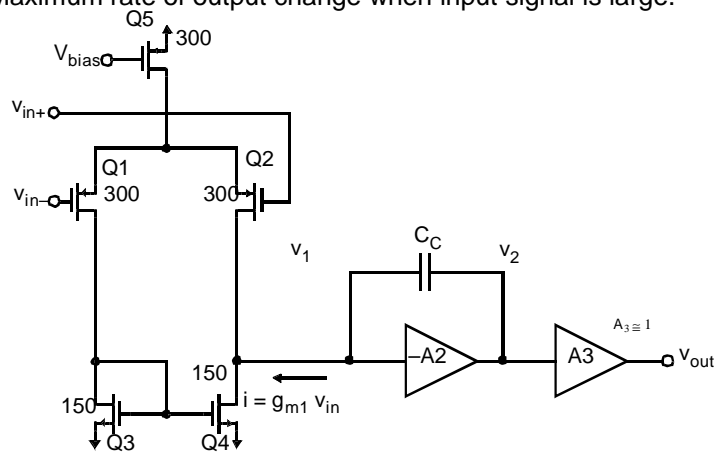

- All the bias current of Q5 goes either into Q1 or Q2.

SM

EECE488 Set 7 - Opamp Design

30

Slew Rate

- Thus

$$SR \equiv \left. \frac{dv_{out}}{dt} \right|_{\max} = \frac{I_{C_C}|_{\max}}{C_C} = \frac{I_{D_5}}{C_C} = \frac{2I_{D_1}}{C_C}$$

I_{D_1} is nominal bias current of input transistors

- Using $C_C = g_{m1}/\omega_{ta}$ and $g_{m1} = \sqrt{2\mu_p C_{ox} \left(\frac{W}{L}\right)_1 I_{D_1}}$

$$SR = \frac{2I_{D_1}}{\sqrt{2\mu_p C_{ox} \left(\frac{W}{L}\right)_1 I_{D_1}}} \omega_{ta} = V_{eff1} \omega_{ta}$$

$$\text{where } V_{eff1} = \sqrt{\frac{2I_{D_1}}{\mu_p C_{ox} \left(\frac{W}{L}\right)_1}}$$

Slew Rate

$$SR = V_{eff1} \omega_{ta}$$

- Normally, the designer has not much control over ω_{ta}
- Slew-rate can be increased by increasing V_{eff1}
- This is one of the reasons for using p-channel input stage: higher slew-rate

Systematic Offset Voltage

- To ensure inherent (systematic) offset voltage does not exist, nominal current through Q7 should equal to that of Q6 when the differential input is zero.

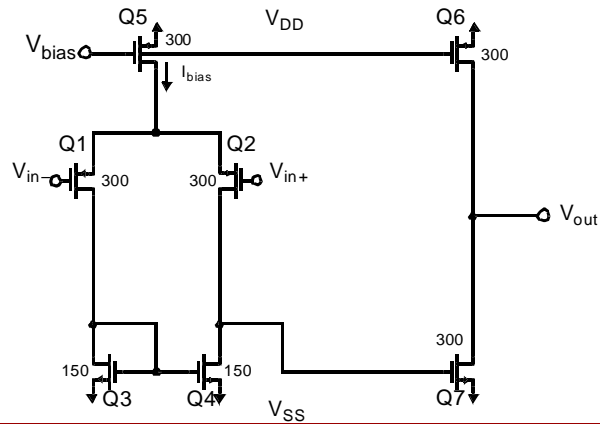

SM

EECE488 Set 7 - Opamp Design

33

Systematic Offset Voltage

- Avoid systematic offset by choosing:

$$\frac{(W/L)_7}{(W/L)_4} = 2 \frac{(W/L)_6}{(W/L)_5}$$

- Found by noting

$$I_{D5} = 2I_{D3} = 2I_{D4}$$

and

$$V_{GS7} = V_{DS3} = V_{GS4}$$

then setting $I_{D7} = I_{D6}$

SM

EECE488 Set 7 - Opamp Design

34

N-Channel versus P-Channel Input Stage

- Complimentary opamp can be designed with an n-channel input differential pair and p-channel second-stage
- Overall gain would be roughly the same in both designs

P-channel Advantages

- Higher slew-rate: for fixed bias current, V_{eff} is larger (assuming similar widths used for maximum gain)
- Higher frequency of operation: higher transconductance of second stage which results in higher unity-gain frequency
- Lower 1/f noise: holes less likely to be trapped; p-channel transistors have lower 1/f noise
- N-channel source follower is preferable (less voltage drop and higher g_m)

N-channel Advantage

- Lower thermal noise — thermal noise is lowered by high transconductance of first stage

SM

EECE488 Set 7 - Opamp Design

35

Feedback and Opamp Compensation

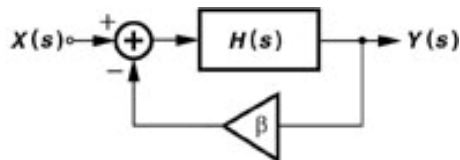

$$\frac{Y}{X}(s) = \frac{H(s)}{1 + \beta H(s)}$$

- Feedback systems may oscillate
- The following two are the oscillation conditions:

$$|\beta H(j\omega)| = 1$$
$$\angle \beta H(j\omega) = -180$$

SM

EECE488 Set 7 - Opamp Design

36

Stable and Unstable Systems

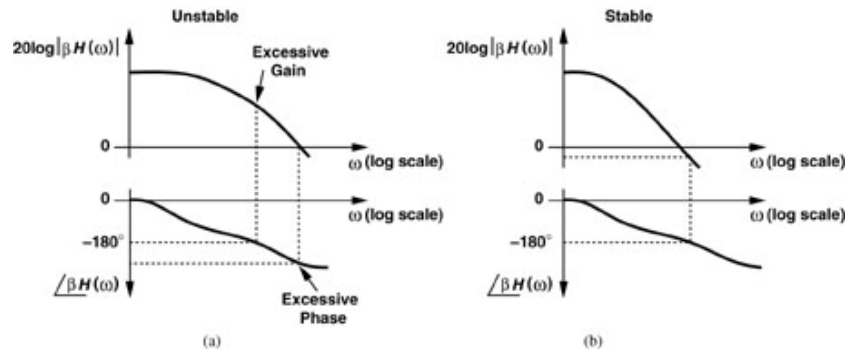

SM

EECE488 Set 7 - Opamp Design

37

Time-domain response of a feedback system

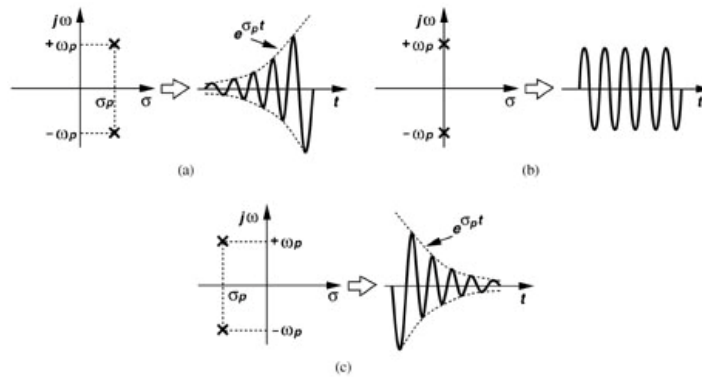

SM

EECE488 Set 7 - Opamp Design

38

One-pole system

$$H(s) = \frac{A_0}{1 + s/\omega_0}$$

$$\frac{Y}{X}(s) = \frac{\frac{A_0}{1 + \beta A_0}}{1 + \frac{s}{\omega_0(1 + \beta A_0)}}$$

$$S_p = -\omega_0(1 + \beta A_0)$$

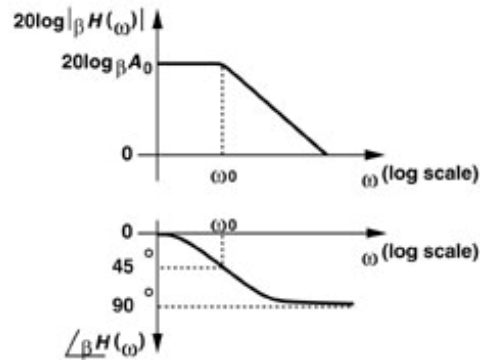

Bode plot of the Loop gain

Multi-pole system

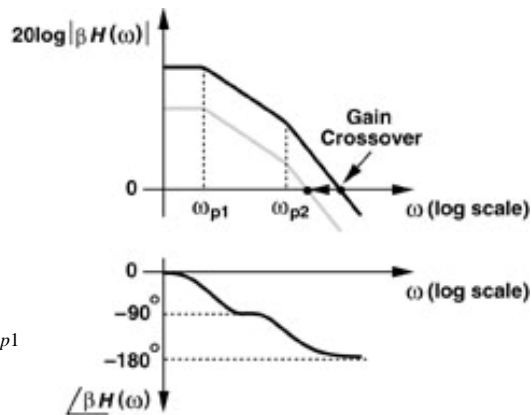

$$0.1\omega_{p2} > 10\omega_{p1}$$

Bode plot of the Loop gain

Phase Margin

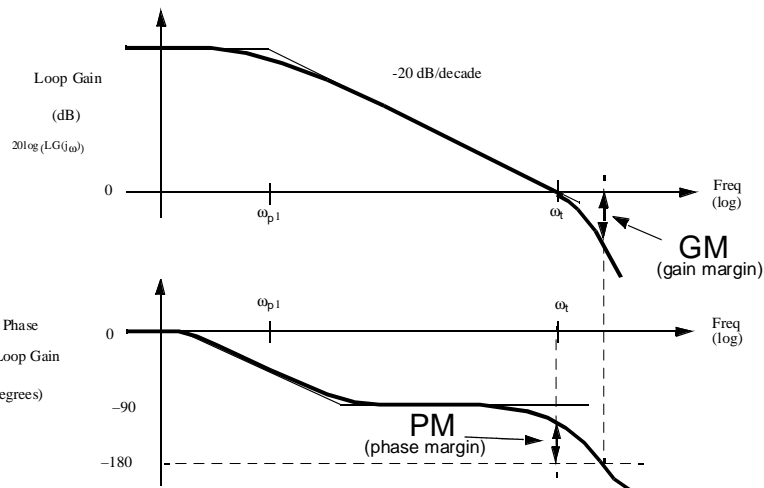

SM

EECE488 Set 7 - Opamp Design

41

Phase Margin

$$\beta H(\omega_1) = 1 \times e^{-j175^\circ}$$

$$\left| \frac{Y}{X}(s) \right| = \frac{11.5}{\beta}$$

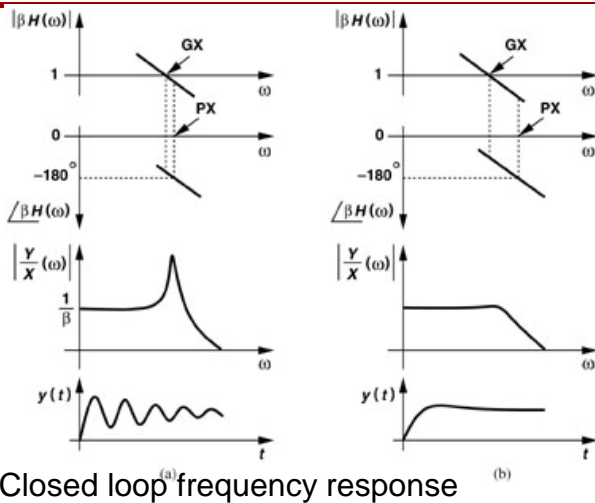

Closed loop frequency response

SM

EECE488 Set 7 - Opamp Design

42

Phase Margin (Cont.)

$$PM = 180 + \angle \beta H(\omega_{GX})$$

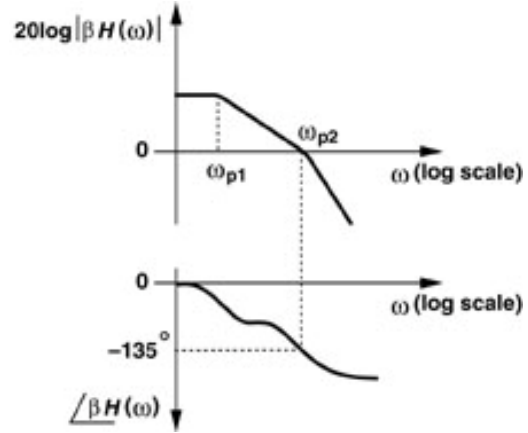

Phase Margin = 45°

SM

EECE488 Set 7 - Opamp Design

43

Phase Margin (Cont.)

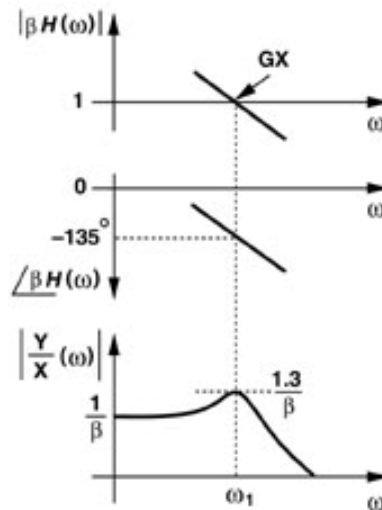

Phase Margin = 45°

SM

EECE488 Set 7 - Opamp Design

44

Phase Margin (Cont.)

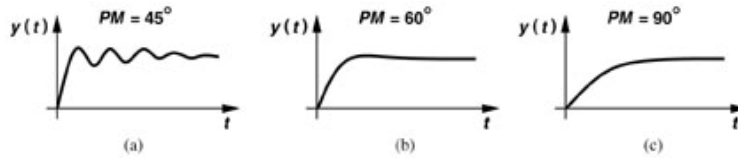

- At $PM = 60^\circ$ results in a small overshoot in the step response.
- If we increase PM, the system will be more stable but the time response slows down.

SM

EECE488 Set 7 - Opamp Design

45

Frequency Compensation

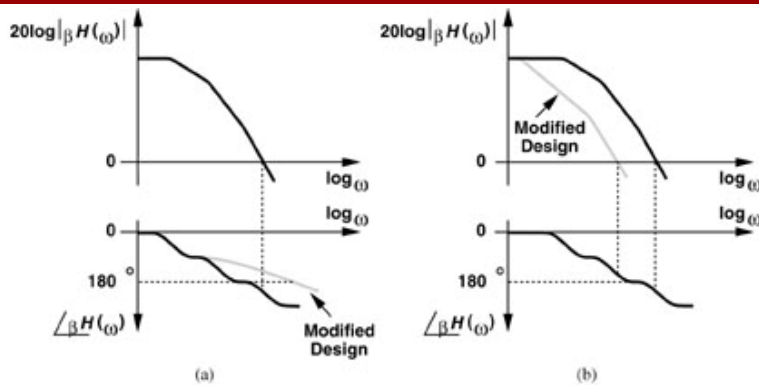

- Push phase crossing point out
- Push gain crossing point in

SM

EECE488 Set 7 - Opamp Design

46

Telescopic Opamp (single-ended) -example

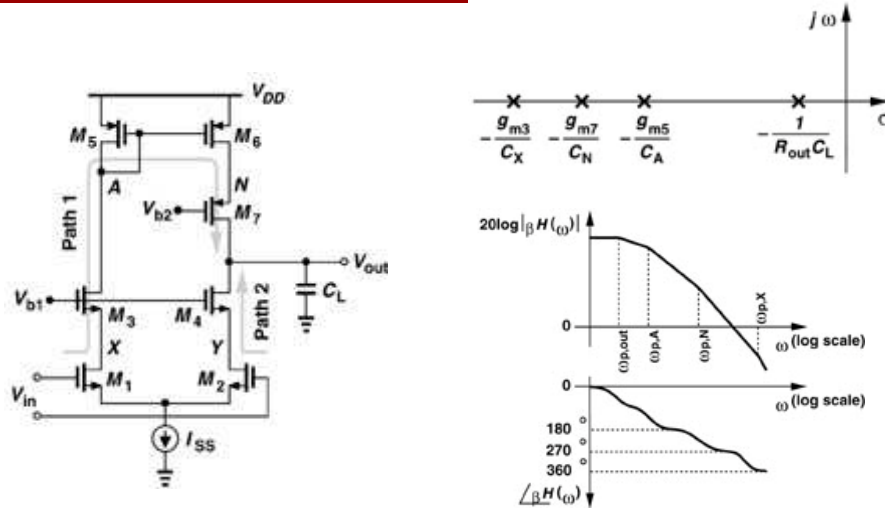

SM

EECE488 Set 7 - Opamp Design

47

Compensation (Cont.)

- Assume we need a phase margin of 45° (usually inadequate) and other non-dominant poles are at high frequency.

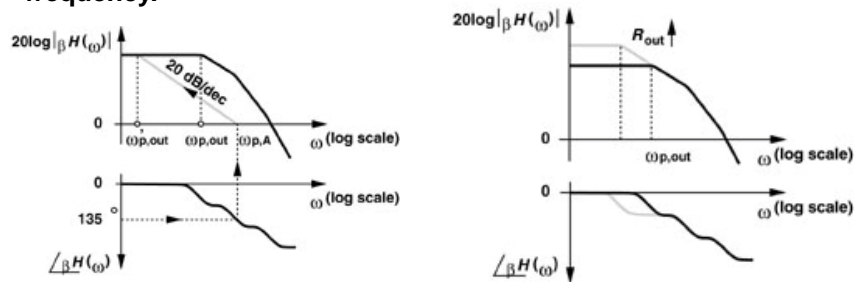

SM

EECE488 Set 7 - Opamp Design

48

Compensation of a two-stage opamp

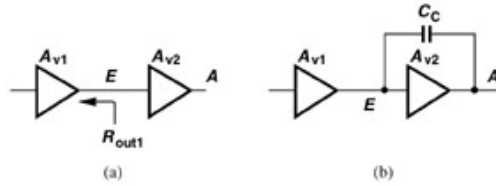

Miller Effect $C_{eq} = C_E + (1 + A_{v2})C_C$

$$f_{pE} = \frac{1}{2\pi R_{out} [C_E + (1 + A_{v2})C_C]}$$

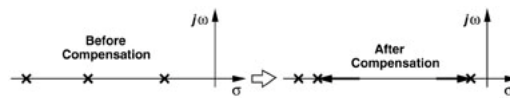

SM

EECE488 Set 7 - Opamp Design

49

Compensating Two-Stage Opamps

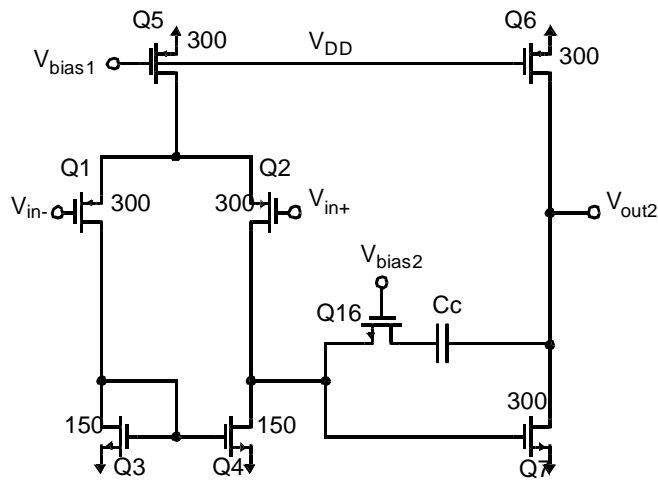

SM

EECE488 Set 7 - Opamp Design

50

Compensating Two-Stage Opamps

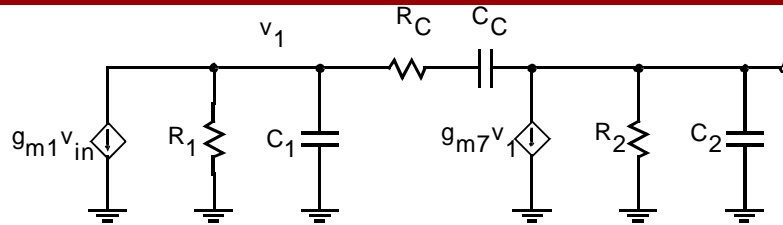

- Q16 has $V_{DS16} = 0$ therefore it is hard in the triode region.

$$R_C = r_{ds16} = \frac{1}{\mu_n C_{ox} \left(\frac{W}{L}\right)_{16} V_{eff16}}$$

- Small signal analysis: without R_C , a right-half plane zero occurs and worsens the phase-margin.

SM

EECE488 Set 7 - Opamp Design

51

Compensating Two-Stage Opamps

- Using R_C (through Q16) places zero at

$$\omega_z = \frac{-1}{C_C(1/g_{m7} - R_C)}$$

- Zero moved to left-half plane to aid compensation
- Good practical choice is

$$\omega_z = 1.2\omega_t$$

- satisfied by letting

$$R_C \cong \frac{1}{1.2g_{m1}}$$

since $\omega_t \cong g_{m1}/C_C$ and $\omega_z \cong 1/(R_C C_C)$ if $R_C \gg 1/g_{m7}$

SM

EECE488 Set 7 - Opamp Design

52

Design Procedure

Design example: Find C_C with $R_C=0$ for a 55° phase margin

- Arbitrarily choose $C'_C=1\text{pF}$ and set $R_C=0$
- Using SPICE, find frequency ω_t where a -125° phase shift exists, define gain as A'
- Choose new C_C so ω_t becomes unity-gain frequency of the loop gain, resulting in a 55° phase margin.
Achieved by setting $C_C=C_C A'$
- Might need to iterate on C_C a couple of times using SPICE

Design Procedure

Next: Choose R_C according to

$$R_C = \frac{1}{1.2\omega_t C_C}$$

- Increasing ω_t by about 20 percent, leaves zero near final ω_t
- Check that gain continues to decrease at frequencies above the new ω_t

Next: If phase margin is not adequate, increase C_C while leaving R_C constant.

Design Procedure

Next: Replace R_C by a transistor

$$R_C = r_{ds16} = \frac{1}{\mu_n C_{ox} \left(\frac{W}{L}\right)_{16} V_{eff16}}$$

SPICE can be used for iteration to fine-tune the device dimensions and optimize the phase margin.

Process and Temperature Independence

- Can show non-dominant pole is roughly given by

$$\omega_{p2} \cong \frac{g_{m7}}{C_1 + C_2}$$

- Recall zero given by

$$\omega_z = \frac{-1}{C_C(1/g_{m7} - R_C)}$$

- If R_C tracks inverse of g_{m7} then zero will track ω_{p2} :

$$R_C = r_{ds16} = \frac{1}{\mu_n C_{ox} (W/L)_{16} V_{eff16}}$$

$$g_{m7} = \mu_n C_{ox} (W/L)_7 V_{eff7}$$

Process and Temperature Independence

- Need to ensure V_{eff16}/V_{eff7} is independent of process and temperature variations

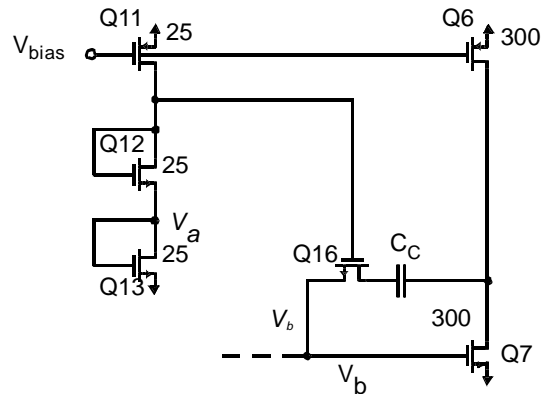

- First set $V_{eff13} = V_{eff7}$ which makes $V_a = V_b$

SM

EECE488 Set 7 - Opamp Design

57

Process and Temperature Independence

$$\sqrt{\frac{2I_{D7}}{\mu_n C_{ox}(W/L)_7}} = \sqrt{\frac{2I_{D13}}{\mu_n C_{ox}(W/L)_{13}}}$$

$$\frac{I_{D7}}{I_{D13}} = \frac{(W/L)_7}{(W/L)_{13}}$$

- Since $V_a = V_b$ and gates of Q12 and Q16 same

$$V_{eff12} = V_{eff16}$$

$$\frac{V_{eff7}}{V_{eff16}} = \frac{V_{eff13}}{V_{eff12}} = \frac{\sqrt{\frac{2I_{D13}}{\mu_n C_{ox}(W/L)_{13}}}}{\sqrt{\frac{2I_{D12}}{\mu_n C_{ox}(W/L)_{12}}}} = \sqrt{\frac{(W/L)_{12}}{(W/L)_{13}}}$$

SM

EECE488 Set 7 - Opamp Design

58

Stable Transconductance Biasing

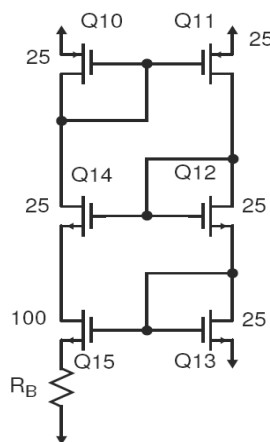

- Can bias on-chip g_m to a resistor

$$V_{GS13} = V_{GS15} + I_{D15} R_B$$

$$\sqrt{\frac{2I_{D13}}{\mu_n C_{ox} (W/L)_{13}}} = \sqrt{\frac{2I_{D15}}{\mu_n C_{ox} (W/L)_{15}}} + I_{D15} R_B$$

- But $I_{D13} = I_{D15}$ and rearrange

$$\frac{2}{\sqrt{2\mu_n C_{ox} (W/L)_{13} I_{D13}}} \left[1 - \sqrt{\frac{(W/L)_{13}}{(W/L)_{15}}} \right] = R_B$$

- Recall $g_{m13} = \sqrt{2\mu_n C_{ox} (W/L)_{13} I_{D13}}$

$$g_{m13} = 2 \left[1 - \sqrt{\frac{(W/L)_{13}}{(W/L)_{15}}} \right] / R_B$$

SM

EECE488 Set 7 - Opamp Design

59

Stable Transconductance Biasing

- Transconductance of Q_{13} (to the first order) is determined by geometric ratios only.
- Independent of power-supply voltages, process parameters, temperature, etc.
- For special case $(W/L)_{15} = 4(W/L)_{13}$

$$g_{m13} = 1/R_B$$

- Note that high-temperature will decrease mobility and hence increase effective gate-source voltages.
- Roughly 25% increase for 100 degree increase
- Requires a start-up circuit (might have all 0 currents)

SM

EECE488 Set 7 - Opamp Design

60