



MTS/MDA Sensor Board Users Manual

Revision B, June 2006

PN: 7430-0020-04



www.xbow.com

© 2002-2006 Crossbow Technology, Inc. All rights reserved.
Information in this document is subject to change without notice.

Crossbow, MoteWorks, MICA, TrueMesh and XMesh are registered trademarks of Crossbow Technology, Inc. Other product and trade names are trademarks or registered trademarks of their respective holders.

Table of Contents

1 Introduction.....1

2 MTS101CA.....2

 2.1 Thermistor..... 2

 2.2 Conversion to Engineering Units..... 3

 2.3 Light Sensor..... 3

 2.4 Prototyping Area..... 4

3 MTS300CA/MTS310CA/MTS300CB/MTS310CB.....6

 3.1 Microphone..... 6

 3.2 Sounder..... 7

 3.3 Light and Temperature..... 7

 3.4 2-Axis Accelerometer (MTS310CA/MTS310CBOnly) 8

 3.5 Two-Axis Magnetometer (MTS310CA/MTS310CB Only) 8

 3.6 Turning Sensors On and Off..... 9

 3.7 Schematics of the MTS300 and MTS310..... 10

4 MTS400CA/MTS420CA/MTS400CB/MTS420CB.....15

 4.1 Humidity and Temperature Sensor 15

 4.2 Barometric Pressure and Temperature Sensor 16

 4.3 Light Sensor..... 16

 4.4 2-Axis Accelerometer 17

 4.5 GPS (MTS420 only)..... 17

 4.6 Turning Sensors On and Off..... 17

 4.7 Schematics of the MTS400 and MTS420..... 18

5 MTS510CA.....19

 5.1 Microphone..... 19

 5.2 Light..... 19

 5.3 2-Axis Accelerometer 19

6 MDA100CA/MDA100CB.....21

 6.2 Conversion to Engineering Units..... 22

 6.3 Light Sensor..... 23

 6.4 Prototyping Area..... 23

7 MDA300CA25

 7.1 Theory of Operation..... 26

8 MDA320CA29

 8.1 Theory of Operation..... 30

9	MDA500CA	33
10	Appendix A: TinyOS Drivers and Test Firmware	34
10.1	Testing a Sensor or Data Acquisition Board	34
11	Appendix B. Warranty and Support Information.....	35
11.1	Customer Service	35
11.2	Contact Directory	35
11.3	Return Procedure.....	35
11.4	Warranty.....	36

About This Document

The following annotations have been used to provide additional information.

◀ NOTE

Note provides additional information about the topic.

☑ EXAMPLE

Examples are given throughout the manual to help the reader understand the terminology.

⚠ IMPORTANT

This symbol defines items that have significant meaning to the user

⚡* WARNING

The user should pay particular attention to this symbol. It means there is a chance that physical harm could happen to either the person or the equipment.

The following paragraph heading formatting is used in this manual:

1 Heading 1

1.1 Heading 2

1.1.1 Heading 3

This document also uses different body text fonts (listed in Table 0-1) to help you distinguish between names of files, commands to be typed, and output coming from the computer.

Table 0-1. Font types used in this document.

Font Type	Usage
Courier New Normal	Sample code and screen output
Courier New Bold	Commands to be typed by the user
<i>Times New Roman Italic</i>	TinyOS files names, directory names
Franklin Medium Condensed	Text labels in GUIs

1 Introduction

The MTS series of sensor boards and MDA series of sensor/data acquisition boards are designed to interface with Crossbow's MICA, MICA2, and MICA2DOT family of wireless Motes. There are a variety of sensor boards available, and the sensor boards are specific to the MICA, MICA2 board or the MICA2DOT form factor. The sensor boards allow for a range of different sensing modalities as well as interface to external sensor via prototyping areas or screw terminals. The following table lists the currently available sensor boards for each Mote family.

Table 1-1. *Crossbow's Sensor and Data Acquisition Boards.*

Chapter	Crossbow Part Name	Motes Supported	Sensors and Features
2	MTS101CA	MICAz, MICA2, MICA	Light, temperature, prototyping area
3	MTS300CA MTS300CB	MICAz, MICA2, MICA	Light, temperature, microphone, and buzzer
3	MTS310CA MTS310CB	MICAz, MICA2, MICA	Light, temperature, microphone, buzzer, 2-axis accelerometer, and 2-axis magnetometer
4	MTS400CA MTS400CB	MICAz, MICA2	Ambient light, relative humidity, temperature, 2-axis accelerometer, and barometric pressure
4	MTS420CA MTS420CB	MICAz, MICA2	Same as MTS400CA plus a GPS module
5	MTS510CA	MICA2DOT	Light, microphone, and 2-axis accelerometer
6	MDA100CA MDA100CB	MICAz, MICA2	Light, temperature, prototyping area
7	MDA300CA	MICAz, MICA2	Light, relative humidity, general purpose interface for external sensors
8	MDA320CA	MICAz, MICA2	General purpose interface for external sensors
9	MDA500CA	MICA2DOT	Prototyping area

2 MTS101CA

The MTS101CA series sensor boards have a precision thermistor, a light sensor/photocell, and general prototyping area. The prototyping area supports connection to five channels of the Mote's analog to digital converter (ADC3–7) and the I2C digital communications bus. The prototyping area also has 24 unconnected holes that are used for breadboard of circuitry.

2.1 Thermistor

The thermistor, (YSI 44006, <http://www.ysi.com>) sensor is a highly accurate and highly stable sensor element. With proper calibration, an accuracy of 0.2 °C can be achieved. The resistance of the thermistor varies with temperature. (See Table 2-1 and the resistance vs. temperature graph in Figure 2-2.) This curve, although non-linear, is very repeatable. The sensor is connected to the analog-digital converter channel number 5 (ADC5, U1 pin 38) thru a basic resistor divider circuit. In order to use the thermistor, the sensor must be enabled by setting digital control line PW2 high. See the circuit below.

Table 2-1. *Thermistor Specifications*

Type	YSI 44006
Time Constant	10 seconds, still air
Base Resistance	10 k Ω at 25 °C
Repeatability	0.2 °C

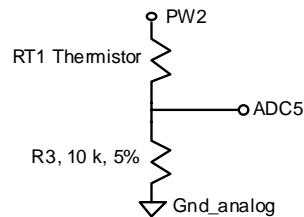

Figure 2-1. *Thermistor Schematic*

Table 2-2. Resistance vs. Temperature, ADC5 Reading

Temperature (°C)	Resistance (Ohms)	ADC5 Reading (% of VCC)
-40	239,800	4%
-20	78,910	11%
0	29,940	25%
25	10,000	50%
40	5592	64%
60	2760	78%
70	1990	83%

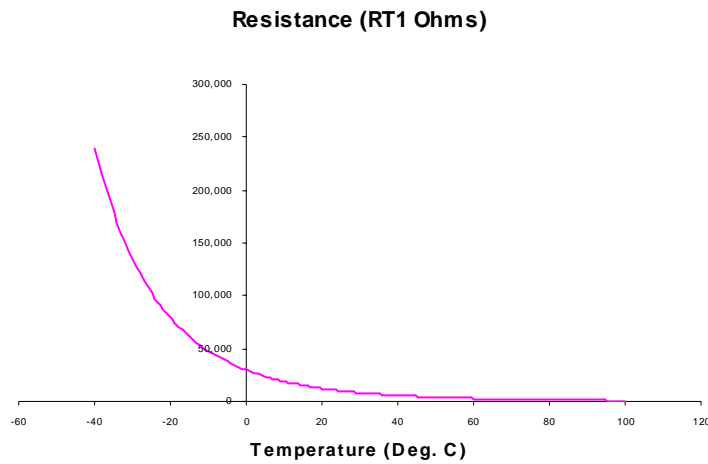

Figure 2-2. Resistance vs. Temperature Graph

2.2 Conversion to Engineering Units

The Mote's ADC output can be converted to Kelvin using the following approximation over 0 to 50 °C:

$$1/T(K) = a + b \times \ln(R_{thr}) + c \times [\ln(R_{thr})]^3$$

where:

$$R_{thr} = R1(ADC_FS-ADC)/ADC$$

$$a = 0.001010024$$

$$b = 0.000242127$$

$$c = 0.000000146$$

$$R1 = 10 \text{ k}\Omega$$

$$ADC_FS = 1023, \text{ and}$$

ADC = output value from Mote's ADC measurement.

2.3 Light Sensor

The light sensor is a CdSe photocell. The maximum sensitivity of the photocell is at the light wavelength of 690 nm. Typical on resistance, while exposed to light, is 2 kΩ. Typical off

resistance, while in dark conditions, is 520 kΩ. In order to use the light sensor, digital control signal PW1 must be turned on. The output of the sensor is connected to the analog-digital converter channel 6 (ADC6, U1 Pin 37). See the circuit below.

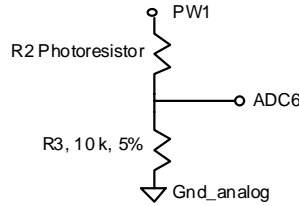

Figure 2-3. Schematic of the light sensor.

Table 2-3. Light Sensor Specifications.

Type	Clairex CL94L
R _{ON}	2 kΩ
R _{OFF}	520 kΩ

2.4 Prototyping Area

The prototyping area is a series of solder holes and connection points for connecting other sensors and devices to the Mote. The prototyping area layout is shown in the diagram and tables below.

Table 2-4. Connection Table for MTS101CA. Use the photo (top view) below the table to locate the pins.

a1-a12	No Connect, Bare Hole	c1-c12	No Connect, Bare Hole
b1	PW4 (U1-33)	b9	I2C_BUS_DATA (U1-22)
b2	PW5 (U1-34)	b10	I2C_BUS_CLK (U1-21)
b3	PW6 (U1-35)	b11	FLASH_SO (U1-19)
b4	ADC3 (U1-36)	b12	FLASH_SI (U1-20)
d1	GND_ANALOG (U1-1)	d9	GND (U1-51)
d2	VDD_ANALOG (U1-2)	d10	VCC (U1-50)
d3	ADC1 (U1-42)	d11	No Connect, Bare Hole
d4	ADC2 (U1-41)	d12	No Connect, Bare Hole
e9	PW3 (U1-32)	e11	ADC0 (U1-43)
e10	ADC4 (U1-39)	e12	GND_ANALOG (U1-1)

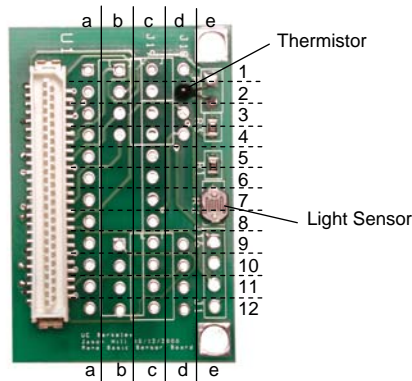

◀ **NOTE:** If you have downloaded the PDF schematic of the Rene basic sensor board from UC Berkeley, you will see that the A/D channels appear in reverse order. This is due to a difference in wiring between the original Rene Mote and the MICA/MICA2 family of Motes.

●* **WARNING:** Never connect signals that are greater than VCC (3V typical) or less than 0 V to any of the holes that connect to the Mote Processor Radio board. It is okay to connect different voltages to the non-connected holes. However, be careful. If a voltage out of the range of 0 to VCC should reach the Mote Processor Radio Board damage **will** occur.

3 MTS300CA/MTS310CA/MTS300CB/MTS310CB

MTS300CA/MTS310CA and MTS300CB/MTS310CB have the same content in this chapter except for some minor changes.

The MTS300 (Figure 3-1a) and MTS310 (Figure 3-1b) are flexible sensor boards with a variety of sensing modalities. These modalities can be exploited in developing sensor networks for a variety of applications including vehicle detection, low-performance seismic sensing, movement, acoustic ranging, robotics, and other applications. The following section of the User's Manual describes the sensor circuits and general application. Please refer to the schematic diagram at end of section for exact circuit details.

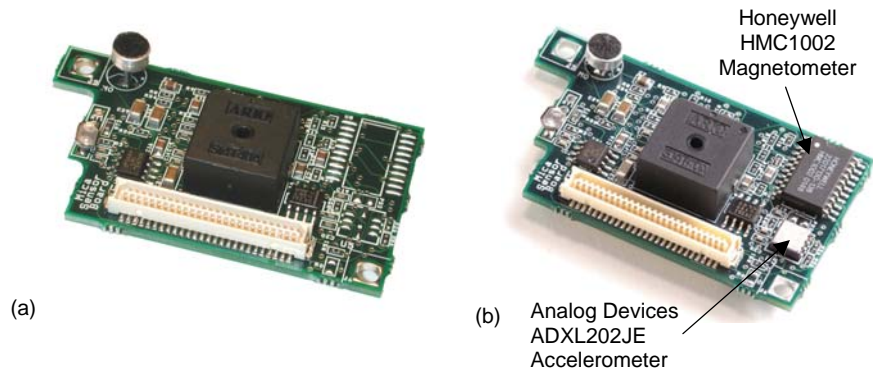

Figure 3-1. (a) MTS300 and (b) MTS310 with the accelerometer and magnetometer highlighted

3.1 Microphone

The microphone circuit has two principal uses: First is for acoustic ranging and second is for general acoustic recording and measurement. The basic circuit consists of a pre-amplifier (U1A-1), second-stage amplified with a digital-pot control (U1A, PT2).

This circuit amplifies the low-level microphone output. This output can be fed directly into the analog-digital converter (ADC2) by using the Microphone Output selector circuit (MX1) to connect mic_out signal to ADC2 signal. This configuration is useful for general acoustic recording and measurement. Audio files have been recorded into the logger flash memory of MICAz, MICA2, or MICA Motes for later download and entertainment (or analysis!).

The second stage output (mic_out) is routed thru an active filter (U2) and then into a tone detector (TD1). The LM567 CMOS Tone Detector IC actually turns the analog microphone signal into a digital high or low level output at INT3 when a 4 kHz tone is present. The Sounder circuit on the sensor board can generate this tone.

A novel application of the sounder and tone detector is acoustic ranging. In this application, a Mote pulses the sounder and sends an RF packet via radio at the same time. A second Mote listens for the RF packet and notes the time of arrival by resetting a timer/counter on its processor. It then increments a counter until the tone detector detects the sounder. The counter value is the time-of-flight of the sound wave between the two Motes. The time-of-flight value can be converted into an approximate distance between Motes. Using groups of Motes with Sounders and Microphones, a crude localization and positioning system can be built

◀ **NOTE:** Motes are designed for power efficiency. Hence all the sensors are disconnected from power on the MTS300 and MTS310 sensor boards unless specifically turned on. See Section 3.6 for more information.

3.2 Sounder

The sounder or “buzzer” is a simple 4 kHz fixed frequency piezoelectric resonator. The drive and frequency control circuitry is built into the sounder. The only signal required to turn the sounder on and off, is Sounder_Power. Sounder_Power is controlled thru the power control switch (P1) and is set by the hardware line PW2.

3.3 Light and Temperature

◀ **NOTE:** The light and temperature sensor share the same A/D converter channel (ADC1). Only turn one sensor on at a time, or the reading at ADC1 will be corrupted and meaningless.

The MTS300 and MTS310 sensor boards have a light sensor and a thermistor.

The light sensor is a simple CdSe photocell. The maximum sensitivity of the photocell is at the light wavelength of 690 nm. Typical on resistance, while exposed to light, is 2 kΩ. Typical off resistance, while in dark conditions, is 520 kΩ. In order to use the light sensor, digital control signal PW1 must be turned on. The output of the sensor is connected to the analog-digital converter channel 1 (ADC1). When there is light, the nominal circuit output is near VCC or full-scale, and when it is dark the nominal output is near GND or zero. Power is controlled to the light sensor by setting signal INT1.

The thermistor (Panasonic ERT-J1VR103J) on the MTS300 and MTS310 is a surface mount component installed at location RT2. It is configured in a simple voltage divider circuit with a nominal mid-scale reading at 25°C. The output of the temperature sensor circuit is available at ADC1.

For MTS300CA and MTS310CA, the thermistor power is controlled by setting signal INT2.

For MTS300CB and MTS310CB, the thermistor power is controlled by setting signal PW0.

Table 3-1. Voltage, Resistance vs. Temperature

Temperature (°C)	Resistance (Ohms)	ADC1 Reading (% of VCC)
-40	427,910	2.3%
-20	114,200	8.1%
0	35,670	22%
25	10,000	50%
40	4090	71%
60	2224	82%
70	1520	87%

3.3.1 Conversion to Engineering Units

The Mote’s ADC output can be converted to degrees Kelvin using the following approximation over 0-50 °C:

$$1/T(K) = a + b \times \ln(R_{thr}) + c \times [\ln(R_{thr})]^3$$

where:

$$R_{thr} = R1(ADC_FS-ADC)/ADC$$

$$a = 0.00130705$$

$$b = 0.000214381$$

$$c = 0.000000093$$

$$R1 = 10 \text{ k}\Omega$$

$$ADC_FS = 1023$$

ADC = output value from Mote's ADC measurement.

3.4 2-Axis Accelerometer (MTS310CA/MTS310CB Only)

The accelerometer is a MEMS surface micro-machined 2-axis, $\pm 2 \text{ g}$ device. It features very low current draw ($< 1\text{mA}$) and 10-bit resolution. The sensor can be used for tilt detection, movement, vibration, and/or seismic measurement. Power is controlled to the accelerometer by setting signal PW4, and the analog data is sampled on ADC3 and ADC4. The accelerometer at location U5 is an ADXL202JE and the full datasheet is available at <http://www.analog.com>. A summary of specification is provided in Table 3-2 below for reference.

Table 3-2. Summary of ADXL202JE Specifications.

Channels	X (ADC3), Y (ADC4)
G-range	$\pm 2 \text{ g}$ ($1 \text{ g} = 9.81 \text{ m/s}^2$)
Bandwidth	DC-50 Hz (controlled by C20, C21)
Resolution	2 mG (0.002 G) RMS
Sensitivity	167 mV/G $\pm 17 \%$
Offset	2.5 V $\pm 0.4 \text{ V}$

⚠ **NOTE:** The ADXL202 sensitivity and offset have a wide initial tolerance. A simple calibration using earth's gravitational field can greatly enhance the accuracy of the ADXL202 sensor. By rotating the sensor into a +1 G and a -1 G position, the offset and sensitivity can be calculated to within 1 %.

3.5 Two-Axis Magnetometer (MTS310CA/MTS310CB Only)

The magnetometer circuit is a silicon sensor that has a unique bridge resistor coated in a highly sensitive NiFe coating. This NiFe coating causes the bridge resistance of the circuit to change. The bridge is highly sensitive and can measure the Earth's field and other small magnetic fields. A useful application is vehicle detection. Successful test have detected disturbances from automobiles at a radius of 15 feet. The sensor is the Honeywell HMC1002 sensor. A detailed specification sheet is found at <http://www.ssec.honeywell.com>. The output of each axis (X, Y) is amplified by an instrumentation amplifier U6, U7. The amplified output is available at ADC5 and ADC6. Power is controlled to the magnetometers by setting signal PW5. Each instrumentation amplifier (U6, U7) can be tuned using the digital potentiometer PT1 that is controlled via the I2C bus.

⚠ **WARNING:** The NiFe core of the magnetic sensor is extremely sensitive. However, it is also subject to saturation. Saturation occurs when the sensor is exposed to a large magnetic field. Unfortunately the MTS310 circuit does not have an automatic saturation recovery circuit (set/reset). This limitation prevents the magnetometer from being useful in applications

requiring DC response (for example compassing). There are four pads label S/R (Set/Reset) available on the PCB for adding an external set/reset circuit.

3.6 Turning Sensors On and Off

All of the sensors have a power control circuit. The default condition for the sensor is off. This design helps minimize power draw by the sensor board.

In order to turn sensors on, control signals are issued to the power switches. Table 3-3 below lists the control settings.

Table 3-3. *Control Settings for the Sounder and Sensors*

Sensor/Actuator	Control Signal
Sounder	PW2
Microphone	PW3
Accelerometer	PW4
Magnetometer	PW5
Temperature (RT2)	INT2/PW0 ¹
Photocell (R2)	INT1
Temperature(RT2)(MTS300CB/MTS310CB)	PW0

◀ **NOTE:** Only one of the INT1 and INT2/PW0 signals should be activated at a time. See Section 3.3.

¹ For MTS300CA and MTS310CA, the RT2 power is controlled by setting signal INT2. For MTS300CB and MTS310CB, the RT2 power is controlled by setting signal PW0.

3.7 Schematics of the MTS300 and MTS310

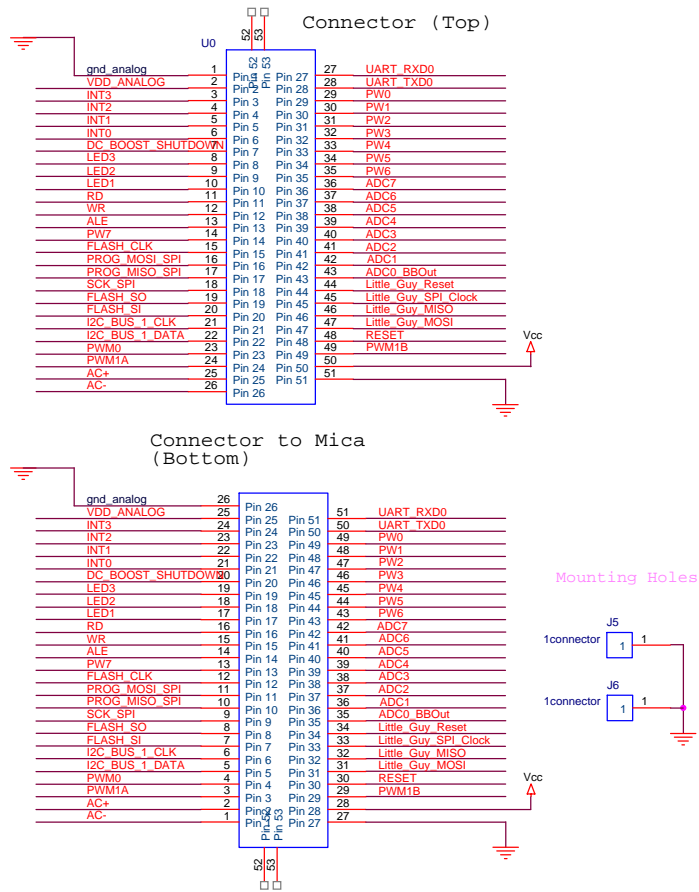

Figure 3-2. MTS300/310 Schematic of 51-pin connector pin-outs

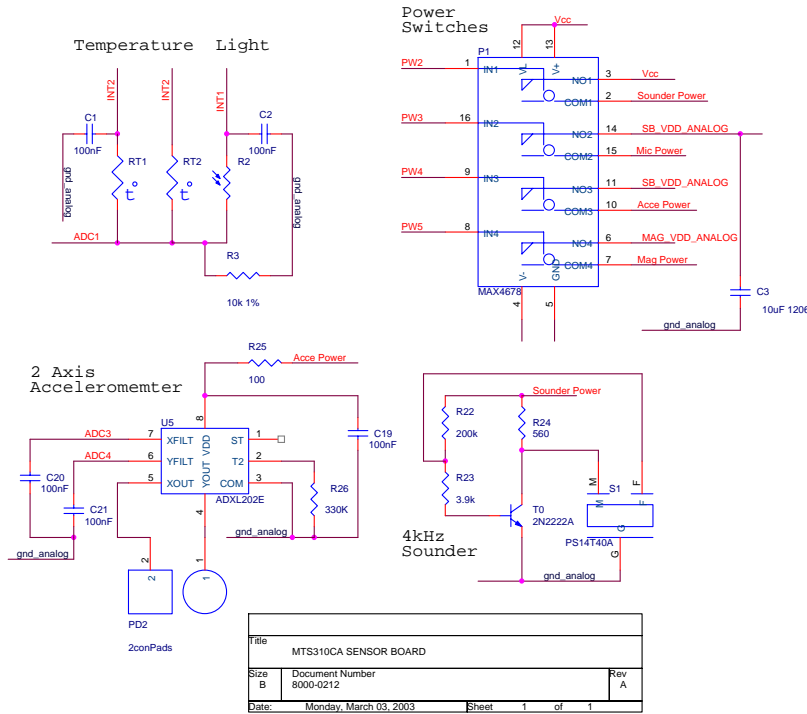

Figure 3-3(a). MTS310CA Schematics of Accelerometer, Sounder, Temperature and Light Sensors, and Power Switches

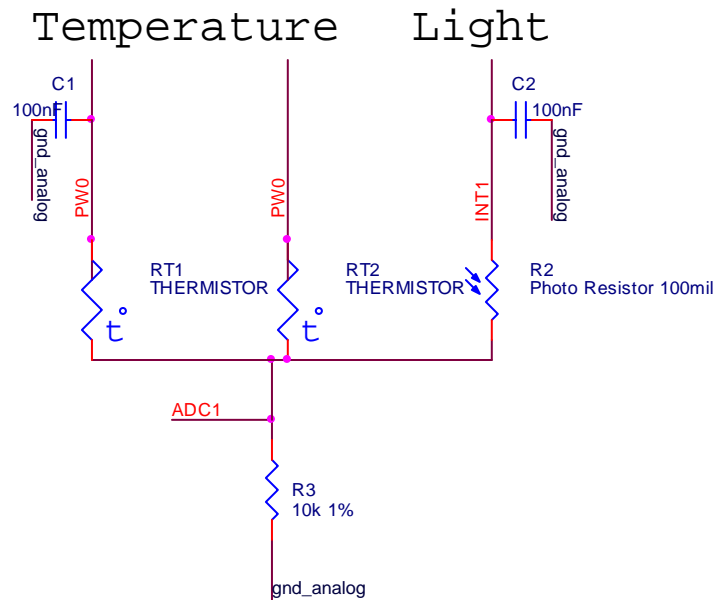

Figure 3-4(b). Power Controlled Signal of MTS300CB/MTS310CB Temperature and Light Sensors

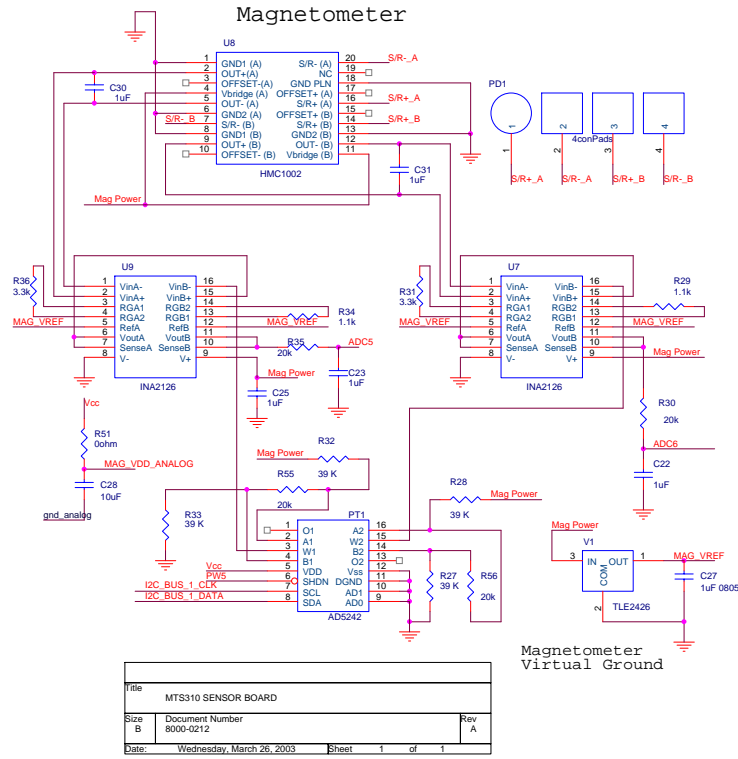

Figure 3-5. MTS310 Schematic of Magnetometer

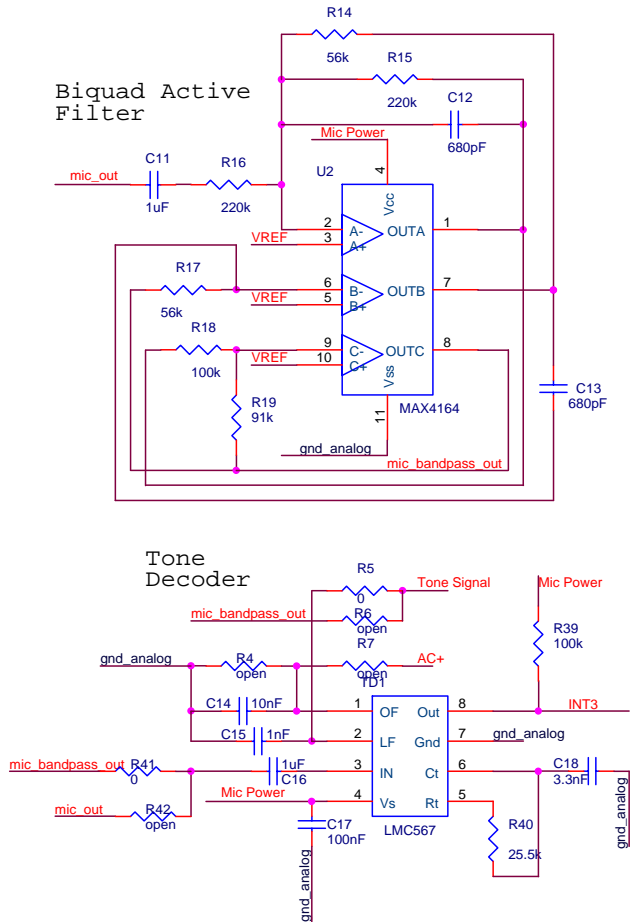

Figure 3-7. MTS310 Schematic of Biquad Active Filter and Tone Decoder

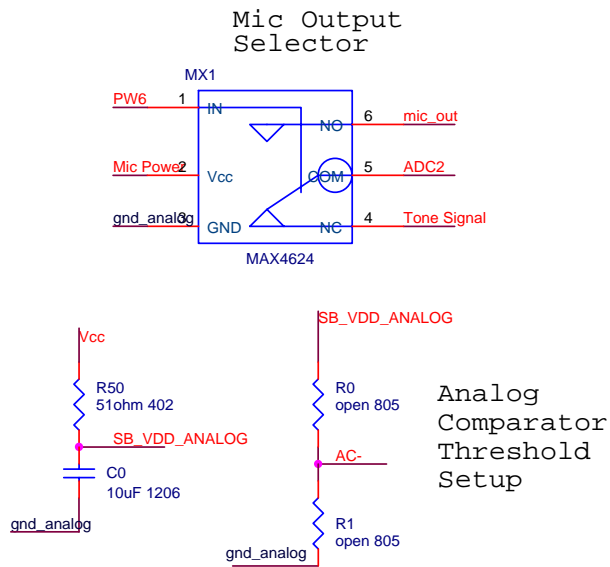

Figure 3-8. MTS310 Schematic of Mic Output Selector and Analog Comparator Threshold Setup

4 MTS400CA/MTS420CA/MTS400CB/MTS420CB

The MTS400CA/MTS420CA and MTS400CB/MTS420CB have the same content in this chapter.

The MTS400 offers five basic environmental sensors with an additional GPS module option (MTS420). The features offered on these boards allows for a wide variety of applications ranging from a simple wireless weather station to a full network of environmental monitoring nodes. Applicable industries include agriculture, industrial, forestry, HVAC and more. These environmental sensor boards utilize the latest generation of energy efficient digital IC-based board-mount sensors. This feature provides extended battery life where a low maintenance, field deployed, sensor node is required.

The GPS module offered on the MTS420 (Figure 4-1) may be used for positional identification of Motes deployed in inaccessible environments and for location tracking of cargo, vehicles, vessels, and wildlife.

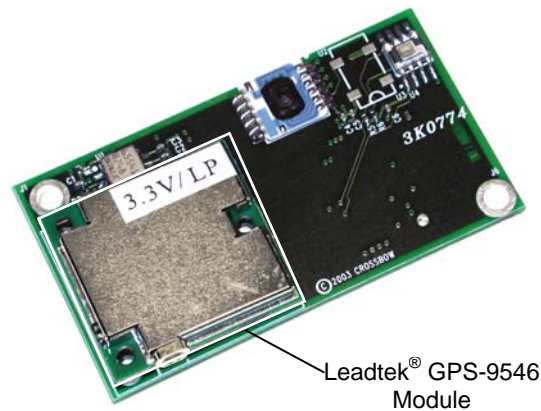

Figure 4-1. Photo of MTS420. The MTS400 does not have the GPS module (highlighted by the box).

◀ **NOTE:** Motes are designed for power efficiency. Hence all the sensors are disconnected from power on the MTS400 and MTS420 sensor boards unless specifically turned on. See Section 4.6 for more information.

4.1 Humidity and Temperature Sensor

The Sensirion® (<http://www.sensirion.com/>) SHT11 is a single-chip humidity and temperature multi sensor module comprising a calibrated digital output. The chip has an internal 14-bit analog-to-digital converter and serial interface. SHT11s are individually calibrated.

Table 4-1. Summary of the Sensirion® SHT11's Specifications

Sensor Type	Sensirion SHT11	
Channels	Humidity	Temperature
Range	0 to 100%	-40°C to 80°C
Accuracy	± 3.5% RH (typical)	± 2°C
Operating Range	3.6 to 2.4 volts	
Interface	Digital interface	

This sensor's power is enabled through a programmable switch. The control interface signals are also enabled through a programmable switch. An analog-to-digital converter in the sensor does the conversion from humidity and temperature to digital units.

4.2 Barometric Pressure and Temperature Sensor

The Intersema® (<http://www.intersema.ch/>) MS55ER is a SMD-hybrid device including a piezoresistive pressure sensor and an ADC interface IC. It provides a 16-bit data word from pressure and temperature measurements. A 3-wire interface is used for all communications.

This sensor's power is enabled through a programmable switch. The control interface signals are also enabled through a programmable switch. An analog-to-digital converter in the sensor does the conversion from pressure and temperature to digital units.

Table 4-2. Summary of the Intersema® MS55ER's Specifications

Sensor Type	Intersema MS5534
Channels	Pressure and Temperature
Range	Pressure: 300 to 110 mbar Temperature: -10°C to 60°C
Accuracy	Pressure: ± 3.5% Temperature: ± 2°C
Operating Range	3.6 to 2.2 volts
Interface	Digital interface

4.3 Light Sensor

The TLS2550 is a digital light sensor with a two-wire, SMBus serial interface. It is manufactured by TAOS, Inc (<http://www.taosinc.com>). It combines two photodiodes and a compounding analog-to-digital converter on a single CMOS integrated circuit to provide light measurements over an effective 12-bit dynamic range. Table 4-3 has a summary of the sensor's specifications.

Table 4-3. Summary of TAOS TSL2550's Specifications

Sensor Type	Taos TSL2550
Channels	Light
Range	400 – 1000 nm
Operating Range	3.6 to 2.7 volts
Interface	Digital interface

This sensor's power is enabled through a programmable switch. The control interface signals are also enabled through a programmable switch. An analog-to-digital converter in the sensor does the conversion from light to digital units.

4.4 2-Axis Accelerometer

The accelerometer is a MEMS surface micro-machined 2-axis, ± 2 g device. It features very low current draw (< 1 mA). The sensor can be used for tilt detection, movement, vibration, and/or seismic measurement. The sensor output's are connected to ADC channels on the Mote's ADC1 and ADC2 channels.

Table 4-4. Summary of the ADXL202JE's Specifications

Sensor Type	Analog Devices ADXL202JE
Channels	X (ADC1), Y (ADC2)
Range	± 2 G (1 G = 9.81 m/s^2)
Sensitivity	167 mV/G, ± 17 %
Resolution	2 mG (0.002 G) RMS
Offset	VBATTERY/2 ± 0.4 V
Operating Range	3.6 to 3.0 V
Interface	Analog interface

◀ **NOTE:** The ADXL202 sensitivity and offset have a wide initial tolerance. A simple calibration using earth's gravitational field can greatly enhance the accuracy of the ADXL202 sensor. By rotating the sensor into a +1 G and a -1 G position, the offset and sensitivity can be calculated to within 1 %.

4.5 GPS (MTS420 only)

The GPS module (Leadtek GPS-9546, <http://www.leadtek.com/>) is powered via a DC-DC booster, which maintains a constant 3.3 volt input regardless of battery voltage. The booster output is programmably enabled. The output from the GPS module is connected to a serial UART, USART1, interface of the Mote. An active, external, antenna is supplied with the module. The GPS module supplies the antenna power.

Table 4-5. Summary of the SiRFstarIIe LP's (GPS 9546) Specifications.

GPS Chipset	SiRFstarIIe LP
Antenna	External active antenna, power supplied by GPS module.
Channels	12
Meters	10 m, 2D
Start Time (sec)	45 Cold; 38 Warm; 8 Hot
Reacquisition Time	0.1 sec (typical, w/o dense foliage)
Protocol	NEMA-0183 and SIRF binary protocol
Current	60 mA at 3.3 V
Interface	Serial interface

◀ **NOTE:** The GPS module's DC-DC booster can interfere with radio communication. If the GPS module must be continually powered and monitored during radio communication, then 3.3-3.6 volt lithium batteries are recommended to power the Mote. Normal alkaline batteries are **not** recommended unless the GPS module is powered down during radio communication.

4.6 Turning Sensors On and Off

Power for all of the sensors on the MTS400/420 sensor board is controlled through an analog power switch at location U7. It can be programmed enable and disable power to individual

sensors. The default condition for the sensors is off. This design helps minimize power draw by the sensor board.

4.7 Schematics of the MTS400 and MTS420

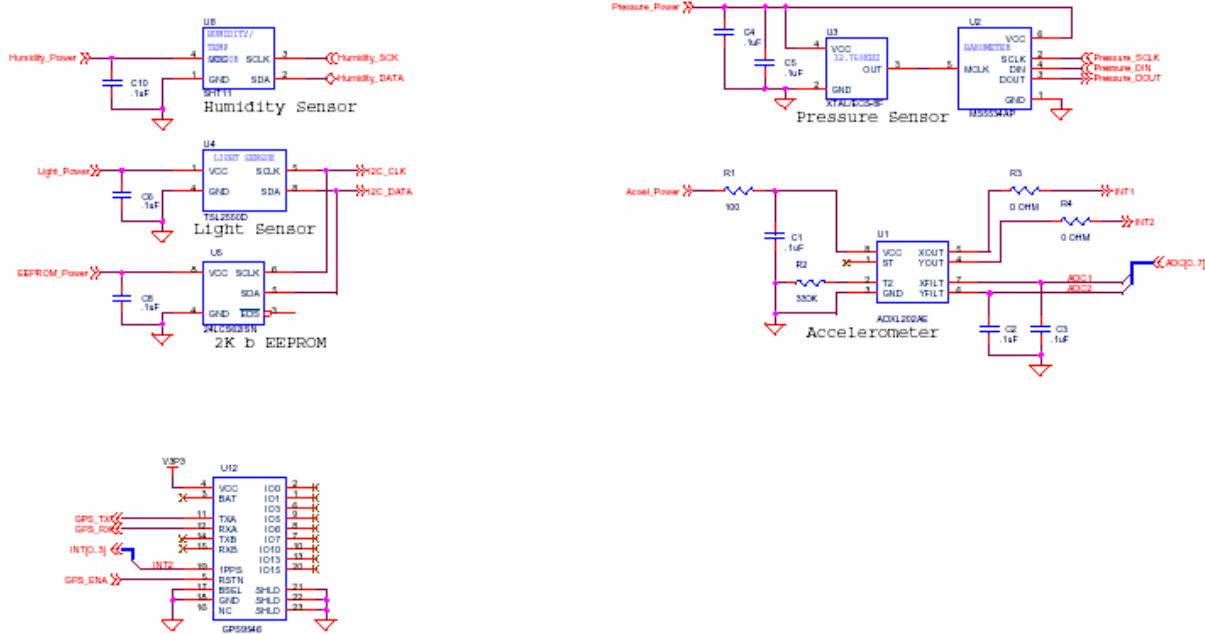

Figure 4-2. MTS400 Sensors Schematic.

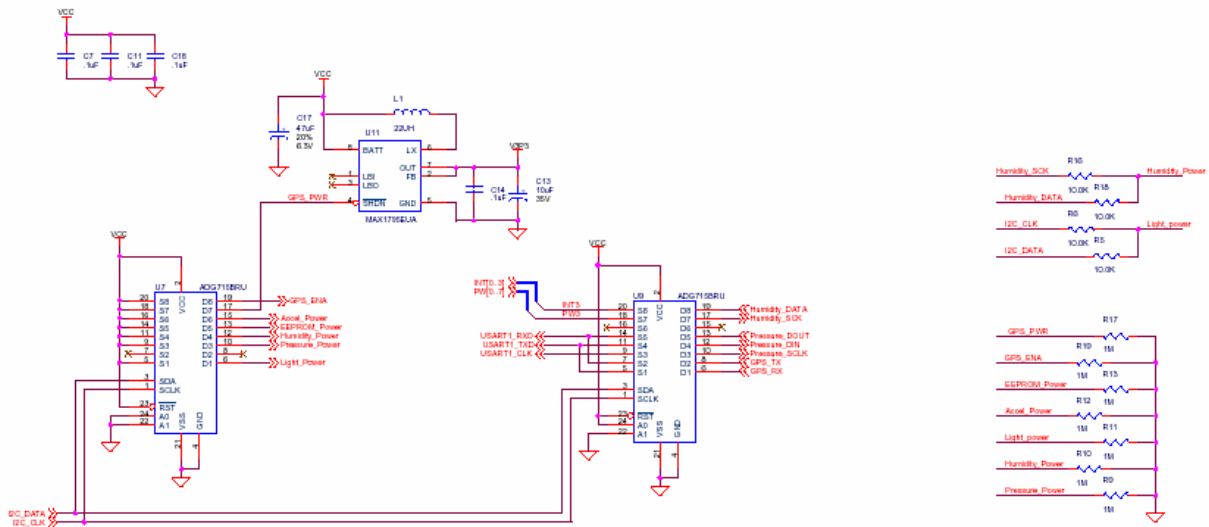

Figure 4-3. MTS400 Power and Signal Control Schematic.

5 MTS510CA

The MTS510CA series sensor is a flexible sensor board with a variety of sensing modalities. These modalities can be exploited in developing sensor networks for a variety of applications including personnel detection, low-performance seismic sensing, movement, robotics, and other applications. The following section of the User's Manual describes the sensor circuits and general application. Please refer to the schematic diagram at end of section for exact circuit details.

5.1 Microphone

The microphone circuit may be used for general acoustic recording and measurement. The basic circuit consists of a pre-amplifier (U4), second-stage amplified with a digital-pot control (U3, U1-A). In order to use the light sensor, digital control signal PW1 must be turned on.

This circuit amplifies the low-level microphone output. This output can be fed directly into the analog-digital converter (ADC2). This configuration is useful for general acoustic recording and measurement. Audio files have been recorded into the Logger Flash memory of MICA, MICA2 Motes for later download and entertainment (or analysis!).

5.2 Light

As on the MTS101CA, the MTS510CA has a light sensor. The light sensor is a simple CdSe photocell. The maximum sensitivity of the photocell is at the light wavelength of 690 nm. Typical on resistance, while exposed to light, is 2 k Ω . Typical off resistance, while in dark conditions, is 520 k Ω .

In order to use the light sensor, digital control signal PW0 must be turned on. The output of the sensor is connected to the analog-digital converter channel 7 (ADC7). When there is light, the nominal circuit output is near VCC or full-scale, and when it is dark the nominal output is near GND or zero.

5.3 2-Axis Accelerometer

The accelerometer is a MEMS surface micro-machined 2-axis, ± 2 g device. It features very low current draw (< 1 mA) and 10-bit resolution. The sensor can be used for tilt detection, movement, vibration, and/or seismic measurement. Power is controlled to the accelerometer by setting signal PW0, and the analog data is sampled on ADC3 and ADC4. The accelerometer, located at U2, is the ADXL202JE and the full datasheet is available at <http://www.analog.com>. A summary of specification is provided in Table 5-1 below for reference.

Table 5-1. Summary of ADXL202JE Specifications.

Channels	X (ADC3), Y (ADC4)
G-range	$\pm 2 \text{ G}$ (1 G = 9.81 m/s^2)
Bandwidth	DC-50 Hz (controlled by C20, C21)
Resolution	2 mG (0.002 G) RMS
Sensitivity	167 mV/G $\pm 17 \%$
Offset	2.5 V $\pm 0.4 \text{ V}$

◀ **NOTE:** The ADXL202 sensitivity and offset have a wide initial tolerance. A simple calibration using earth's gravitational field can greatly enhance the accuracy of the ADXL202 sensor. By rotating the sensor into a +1 G and a -1 G position, the offset and sensitivity can be calculated to within 1 %.

6 MDA100CA/MDA100CB

MD100CA and MDA100CB have the same content in this chapter except for some minor changes.

The MDA100 series sensor boards have a precision thermistor, a light sensor/photocell, and general prototyping area. The prototyping area supports connection to all eight channels of the Mote's analog to digital converter (ADC0-7), both USART serial ports and the I2C digital communications bus. The prototyping area also has 45 unconnected holes that are used for breadboard of circuitry.

6.1.1 Thermistor

The thermistor, (YSI 44006, <http://www.ysi.com>) sensor is a highly accurate and highly stable sensor element. With proper calibration, an accuracy of 0.2 °C can be achieved. The thermistor's resistance varies with temperature. (See Table 6-1 and the resistance vs. temperature graph in Figure 6-3) This curve, although non-linear, is very repeatable. The sensor is connected to the analog-digital converter channel number 1 (ADC1) thru a basic resistor divider circuit. In order to use the thermistor, the sensor must be enabled by setting digital control line INT2 high. See the Figure 6-1 below.

Table 6-1. Thermistor Specifications

Type	YSI 44006
Time Constant	10 seconds, still air
Base Resistance	10 kΩ at 25 °C
Repeatability	0.2 °C

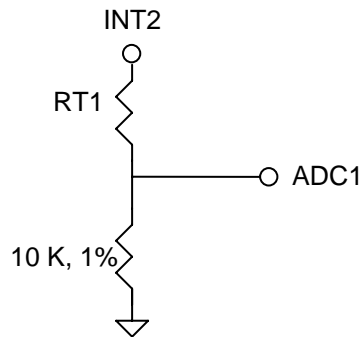

Figure 6-1(a). Schematic of the Thermistor on MDA100CA

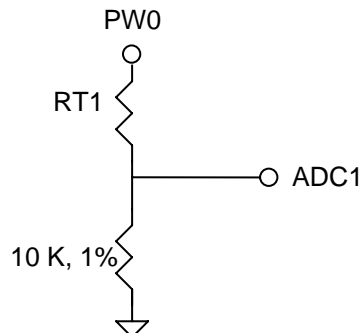

Figure 6-2(b). Schematic of the Thermistor on MDA100CB

Table 6-2. Resistance vs. Temperature, ADC1 Reading

Temperature (°C)	Resistance (Ohms)	ADC5 Reading (% of VCC)
-40	239,800	4%
-20	78,910	11%
0	29,940	25%
25	10,000	50%
40	5592	64%
60	2760	78%
70	1990	83%

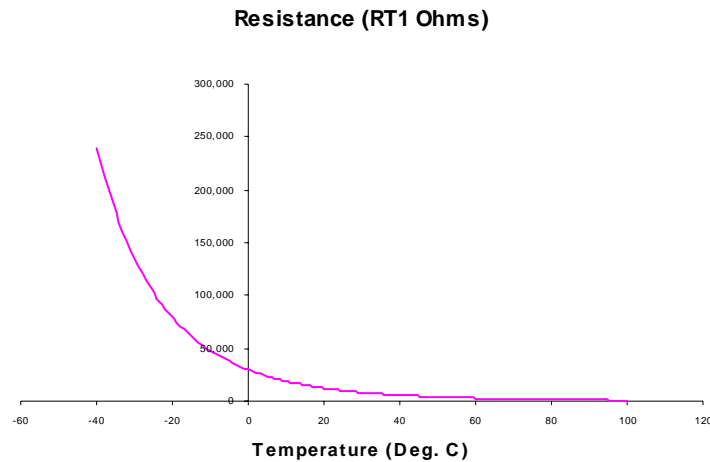

Figure 6-3. Resistance vs. Temperature Graph

6.2 Conversion to Engineering Units

The Mote's ADC output can be converted to Kelvin using the following approximation over 0 to 50 °C:

$$1/T(K) = a + b \times \ln(R_{thr}) + c \times [\ln(R_{thr})]^3$$

where:

$$R_{thr} = R1(ADC_FS-ADC)/ADC$$

$$a = 0.001010024$$

$$b = 0.000242127$$

$$c = 0.000000146$$

$$R1 = 10 \text{ k}\Omega$$

$$ADC_FS = 1023, \text{ and}$$

ADC = output value from Mote's ADC measurement.

6.3 Light Sensor

The light sensor is a simple CdSe photocell. The maximum sensitivity of the photocell is at the light wavelength of 690 nm. Typical on resistance, while exposed to light, is 2 k Ω . Typical off resistance, while under dark conditions, is 520 k Ω . In order to use the light sensor, digital control signal PW1 must be turned on. The output of the sensor is connected to the analog-digital converter channel 1 (ADC1). When there is light, the nominal circuit output is near VCC or full-scale, and when it is dark the nominal output is near GND or zero. Power is controlled to the light sensor by setting signal INT2.

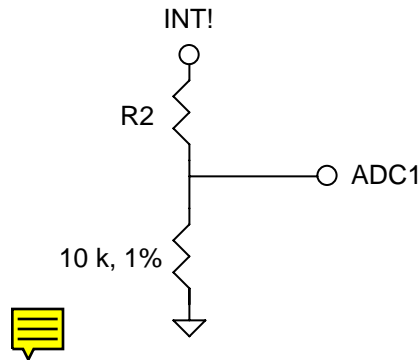

Figure 6-4. Schematic of the light sensor

6.4 Prototyping Area

The prototyping area is a series of solder holes and connection points for connecting other sensors and devices to the Mote. The prototyping area layout is shown in the diagram and tables below.

Table 6-3. Connection Table for MDA100. Use the photo (top view) below the table to locate the pins.

	A	B	C	D	E	F
1	GND	GND	GND	VCC	VCC	VCC
2	OPEN	OPEN	USART1_CK	INT3	ADC2	PW0
3	OPEN	OPEN	UART0_RX	INT2 [†]	ADC1 [†]	PW1 [†]
4	OPEN	OPEN	UART0_TX	INT1	ADC0 [†]	PW2
5	OPEN	OPEN	SPI_SCK	INT0	THERM_PWR	PW3
6	OPEN	OPEN	USART1_RX	BAT_MON	THRU1	PW4
7	OPEN	OPEN	USART1_TX	LED3	THRU2	PW5
8	OPEN	OPEN	I2C_CLK	LED2	THRU3	PW6
9	OPEN	OPEN	I2C_DATA	LED1	RSTN	ADC7
10	OPEN	OPEN	PWM0	RD	PWM1B	ADC6
11	OPEN	OPEN	PWM1A	WR	OPEN	ADC5
12	OPEN	OPEN	AC+	ALE	OPEN	ADC4
13	OPEN	OPEN	AC-	PW7	OPEN	ADC3
14	GND	GND	GND	VCC	VCC	VCC
15	OPEN	OPEN	OPEN	OPEN	OPEN	OPEN
16	OPEN	OPEN	OPEN	OPEN	OPEN	OPEN
17	OPEN	OPEN	OPEN	OPEN	OPEN	OPEN

[†]Shared functionality

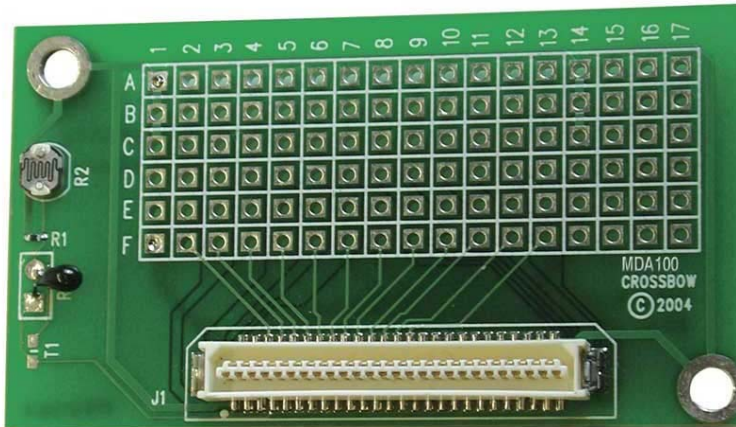

⚠ WARNING: Never connect signals that are greater than VCC (3V typical) or less than 0 V to any of the holes that connect to the Mote Processor Radio board. It is okay to connect different voltages to the non-connected holes. However, be careful. If a voltage out of the range of 0 to Vcc should reach the Mote Processor Radio Board damage will occur.

7 MDA300CA

⚡ WARNING: The MDA300CA can be damaged by ESD. ESD damage can range from subtle performance degradation to complete device failure.

MDA300CA is designed as a general measurement platform for the MICAz and MICA2 (see Figure 7-1). Its primary applications are a) wireless low-power instrumentation, b) weather measurement systems, c) precision agriculture and irrigation control, d) habitat monitoring, e) soil analysis, and f) remote process control.

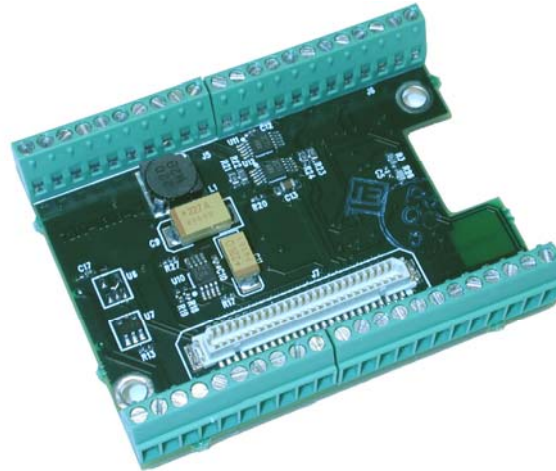

Figure 7-1. Top view of an MDA300CA. This is the side a MICAz or MICA2 Mote would be attached.

Analog sensors can be attached to different channels based on the expected precision and dynamic range. Digital sensors can be attached to the provided digital or counter channels. Mote samples analog, digital or counter channels and can actuate via digital outputs or relays. The combination of a MICAz (MPR2400CA) or MICA2 (MPR400CB) and a MDA300CA can be used as a low-power wireless data acquisition device or process control machine. Table 7-1 below gives the absolute maximum ratings for various electrical parameters.

Table 7-1. The MDA300CAs Absolute Maximum Ratings

+VDD to GND*	-0.3V to +5.5V
Digital Lines:	
Input voltage range**	-0.5 V to $V_{DD} + 0.5$ V
Continuous output low current	50 mA
Continuous output high current	-4 mA
Analog Lines:	
Input voltage range	-0.2 V to $V_{CC} + 0.5$ V
Counter Line:	
Input voltage range	0 V to 5.5V
Relays:	
Maximum Contact Voltage	100V
Maximum Contact Current	150mA

*Users are strongly encouraged to stay within the MICAz or MICA2 nominal input voltage of 2.7 to 3.3 VDC

**The input negative-voltage ratings may be exceeded if the input and output current ratings are observed.

7.1 Theory of Operation

This section briefly describes the operation of the pins available on the MDA300CA. A drawing of the pin-outs and their description is shown in Figure 7-2 below.

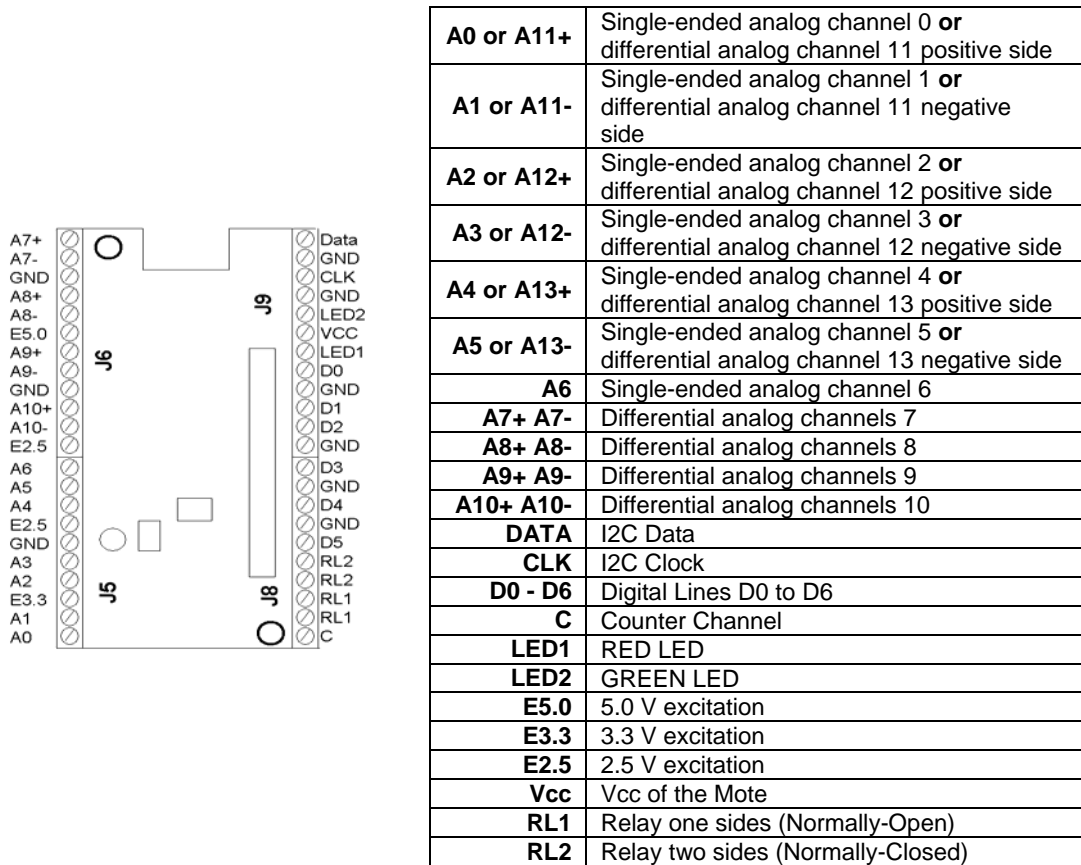

Figure 7-2. Pin configuration and assignments of the MDA300CA

7.1.1 Single Ended Analog Operation (Channels A0 to A6).

NOTE: These channels are shared with differential channels A11–A13 and both of them cannot be used at the same time.

Signals with dynamic range of 0 to 2.5 V can be plugged to these channels. The least significant bit value is 0.6 mV. The result of ADC can be converted to voltage knowing that

$$\text{Voltage} = 2.5 \times \text{ADC_READING} / 4096$$

Resistors need to be added (soldered) to the MDA300CA board to properly scale the voltage levels of external analog sensors so that the maximum voltage is 2.5 VDC. There are two scaling-resistors— R_A and R_B —associated with each ADC channel. These resistors form a simple two-resistor voltage divider. Therefore, choose values for R_A and R_B such that the quantity $R_B / (R_A + R_B)$ multiplied by the maximum output of the sensor is ≤ 2.5 V. The resistors corresponding to a specific ADC channel are listed in Table 7-2 and the area on the board is shown in Figure 7-3 below.

◀ **NOTE:** The resistors in positions R30 to R36 are 0 Ω resistors and would need to be removed when soldering the corresponding resistor for that channel.

Table 7-2. Analog Inputs and Resistor Locations for Voltage Scaling.

ADC Channel	R _A	R _B
0	R36	R43
1	R35	R42
2	R34	R41
3	R33	R40
4	R32	R39
5	R31	R38
6	R28	R37

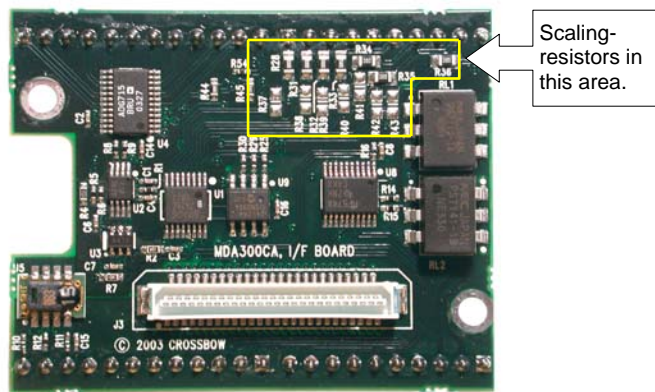

Figure 7-3. Photo of backside of the MDA300CA.

7.1.2 Differential Analog Signals (Channels A11 to A13)

Channels A11 to A13 can be used for differential analog signals. Dynamic range and conversion formula are the same as the single ended channels.

7.1.3 Differential Precision Analog Signals (Channels A7 to A10)

Channels A7 to A10 are precision differential channels. They have a sensor front end with gain of 100. Dynamic range of these channels is ±12.5 mV. The offset is cancelled by measurement of the constant offset and writing it to the E2PROM for software cancellation. The result of the ADC can be converted to voltage (in mV) knowing that

$$\text{Voltage} = 12.5 \times (\text{ADC_READING} / 2048 - 1)$$

7.1.4 Digital Channels (Channels D0 to D5).

Channels D0–D5 are digital channels that can be used for digital input or output. They can be used for counting external phenomena, triggering based on external events or for actuating external signal.

The result of these channels can be saved to the EEPROM for totalizing sensors to avoid losing count in case of power reset. These channels can be protected against switch bouncing. When they are set as inputs they have internal pull-up resistance so that they can be plugged to switch (close-open) sensors.

7.1.5 Counter Channel

This channel is appropriate for high-speed counting or frequency measurement. It has a Schmitt triggered front-end.

7.1.6 Internal Channels

There is an internal sensor for temperature and humidity. This can be used for monitoring the health of the system. It can also be used for “cold junction compensation” in thermocouple measurement applications. The voltage of the device also can be read using the MICAz's or MICA2's internal monitor to have lifetime information.

7.1.7 Relay Channels

There are two relay channels that can be used for actuation of external phenomena. Both relays are optical solid state for maximum isolation and minimum power consumption. One relay is normally open and the other one is normally closed.

7.1.8 External Sensors Excitation

There are three excitation voltages—5.0 V, 3.3 V, and 2.5 V—available for exciting external sensors. They can be used for turning on active external sensors or they can be used in half bridge or full bridge sensors such as strain gauge, force or pressure measurement.

7.1.9 LEDs

LED signals are brought out for applications that use Motes inside enclosures and want to bring the LEDs to the case.

7.1.10 Power Supply (VCC)

It can be used for an external battery attachment.

8 MDA320CA

⚠️ WARNING: The MDA320CA can be damaged by ESD. ESD damage can range from subtle performance degradation to complete device failure.

MDA320CA is designed as a general measurement platform for the MICAz and MICA2 (see Figure 8-1). Its primary applications are a) wireless low-power instrumentation, b) weather measurement systems, c) precision agriculture and irrigation control, d) habitat monitoring, e) soil analysis, and f) remote process control.



Figure 8-1. Top view of an MDA320CA. This is the side a MICAz or MICA2 Mote would be attached.

Analog sensors can be attached to different channels based on the expected precision and dynamic range. Digital sensors can be attached to the provided digital or counter channels. Mote samples analog, digital or counter channels and can actuate via digital outputs. The combination of a MICAz (MPR2400CA) or MICA2 (MPR400CB) and a MDA320CA can be used as a low-power wireless data acquisition device or process control machine. The table below gives the absolute maximum ratings for various electrical parameters.

Table 8-1. The MDA320CAs Absolute Maximum Ratings

+VDD to GND*	-0.3V to +5.5V
Digital Lines:	
Input voltage range**	-0.5 V to $V_{DD} + 0.5 V$
Continuous output low current	50 mA
Continuous output high current	-4 mA
Analog Lines:	
Input voltage range	-0.2 V to $V_{CC} + 0.5 V$
Counter Line:	
Input voltage range	0 V to 5.5V
Relays:	
Maximum Contact Voltage	100V
Maximum Contact Current	150mA

*Users are strongly encouraged to stay within the MICAz or MICA2 nominal input voltage of 2.7 to 3.3 VDC

**The input negative-voltage ratings may be exceeded if the input and output current ratings are observed.

8.1 Theory of Operation

This section briefly describes the operation of the pins available on the MDA320CA. A drawing of the pin-outs and their description is shown in Figure 8-2 below.

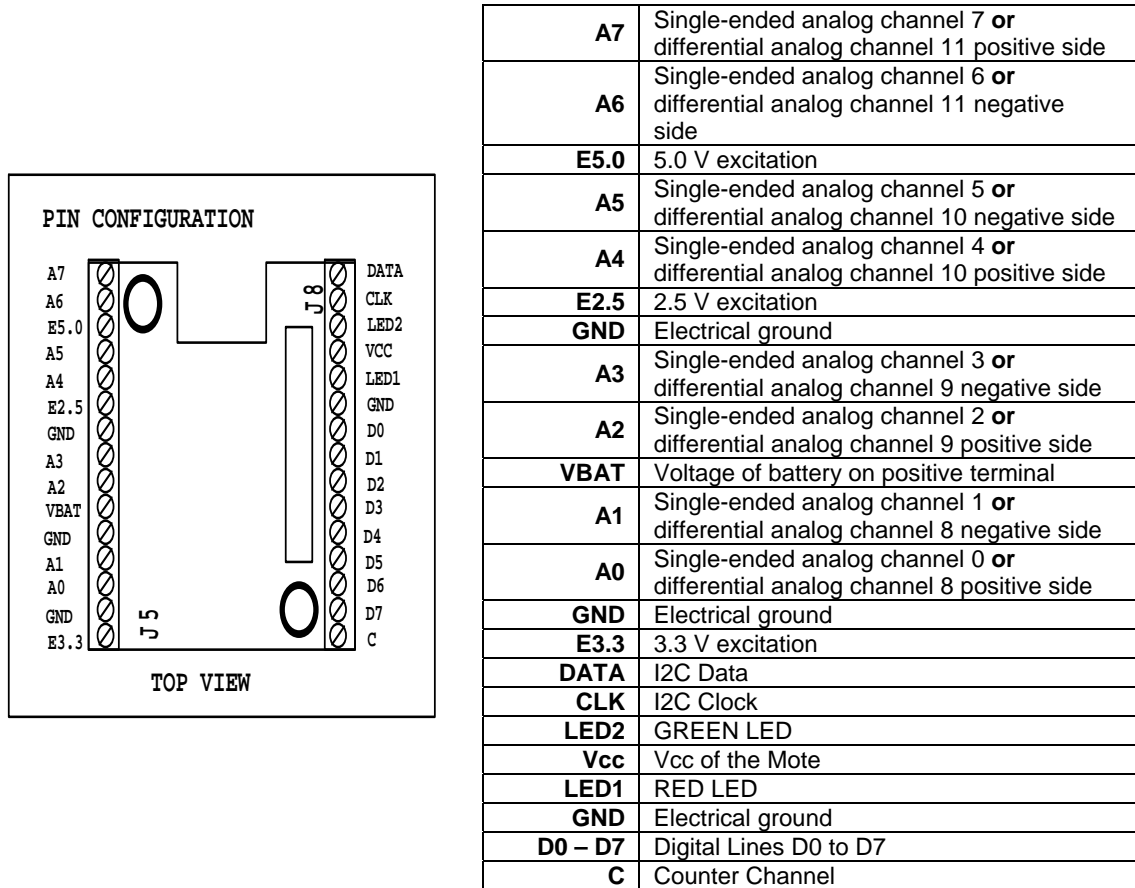

Figure 8-2. Pin configuration and assignments of the MDA300CA

8.1.1 Single Ended Analog Operation (Channels A0 to A7).

Signals with dynamic range of 0 to 2.5 V can be plugged to these channels. The analog to digital converter has 16-bit resolution. The least significant bit value is 0.6 mV. The result of ADC can be converted to voltage knowing that

$$\text{Voltage} = 2.5 \times \text{ADC_READING} / 65536$$

Resistors need to be added (soldered) to the MDA320CA board to properly scale the voltage levels of external analog sensors so that the maximum voltage is 2.5 VDC. There are two scaling-resistors— R_A and R_B —associated with each ADC channel. These resistors form a simple two-resistor voltage divider. Therefore, choose values for R_A and R_B such that the quantity $R_B/(R_A+R_B)$ multiplied by the maximum output of the sensor is ≤ 2.5 V. The resistors corresponding to a specific ADC channel are listed in Table 8-2 and the area on the board is shown in Figure 8-3 below.

◀ **NOTE:** The resistors in positions R28, R31 to R36 and R61 are 0 Ω resistors and would need to be removed when soldering the corresponding resistor for that channel.

Table 8-2. Analog Inputs and Resistor Locations for Voltage Scaling.

ADC Channel	R _A	R _B
0	R36	R43
1	R35	R42
2	R34	R41
3	R33	R40
4	R32	R39
5	R31	R38
6	R28	R37
7	R61	R62

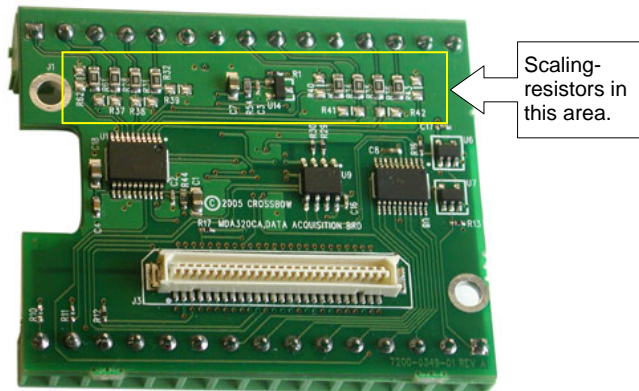

Figure 8-3. Photo of backside of the MDA320CA.

8.1.2 Differential Analog Signals

Channels A0 to A7 can also be used for differential analog signals. Dynamic range and conversion formula are the same as the single ended channels.

8.1.3 Digital Channels (Channels D0 to D7).

Channels D0–D7 are digital channels that can be used for digital input or output. They can be used for counting external phenomena, triggering based on external events or for actuating external signal.

The result of these channels can be saved to the EEPROM for totalizing sensors to avoid losing count in case of power reset. These channels can be protected against switch bouncing. When they are set as inputs they have internal pull-up resistance so that they can be plugged to switch (close-open) sensors.

8.1.4 Counter Channel

This channel is appropriate for high-speed counting or frequency measurement. It has a Schmitt triggered front-end.

8.1.5 External Sensors Excitation

There are three excitation voltages—5.0 V, 3.3 V, and 2.5 V—available for exciting external sensors. They can be used for turning on active external sensors or they can be used in half bridge or full bridge sensors such as strain gauge, force or pressure measurement.

8.1.6 LEDs

LED signals are brought out for applications that use Motes inside enclosures and want to bring the LEDs to the case.

8.1.7 Power Supply (VCC)

It can be used for an external battery attachment.

9 MDA500CA

⚠ WARNING. Never connect signals that are greater than VCC (3 V typical) or less than 0 V to any of the holes that connect to the Mote Processor Radio board. It is okay to connect different voltages to the non-connected holes. However, be careful. If a voltage out of the range of 0–VCC should reach the Mote Processor Radio Board damage will occur.

The MDA500 series sensor / data acquisition provides a flexible user-interface for connecting external signals to the MICA2DOT Mote (Figure 9-1). All of the major I/O signals of the MICA2DOT Mote are routed to plated-thru holes on the MDA500 circuit board. The schematic for this board is shown in Figure 9-2 below.



Figure 9-1. Photo of top-side of an MDA500CA for the MICA2DOT.

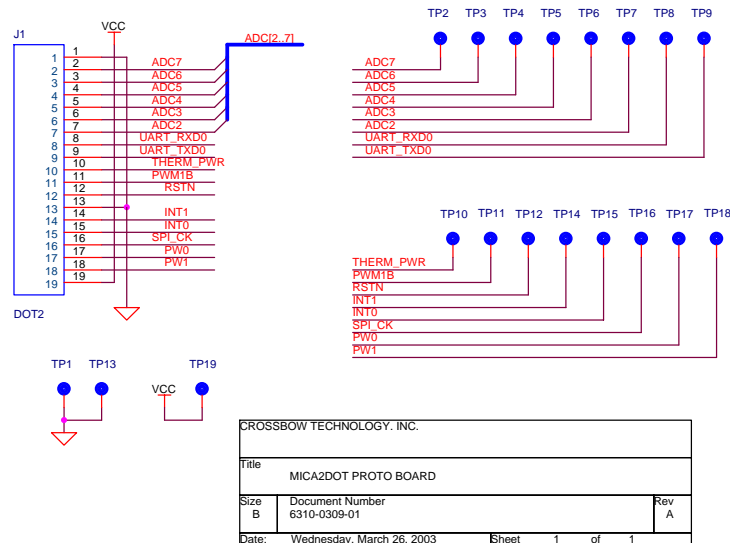

Figure 9-2. Schematic of the MDA500CA

10 Appendix A: TinyOS Drivers and Test Firmware

This section summarizes the drivers and test firmware for Crossbow's sensor and data acquisition boards. Table 10-1 below lists the names of the test and demo application firmware for the various sensor and data acquisition boards.

Table 10-1. Listing of Sensor/DAQ boards, test and demo application.

Sensor or DAQ Board	Test and Demo Application Name(s)
MTS Board	
MTS101	<i>XMTS101_xxx_<mode>.exe</i>
MTS300	<i>XMTS300_xxx_<mode>.exe</i>
MTS310	<i>XMTS310_xxx_<mode>.exe</i>
MTS400	<i>XMTS400_xxx_<mode>.exe</i>
MTS420	<i>XMTS420_xxx_<mode>.exe</i>
MTS510	<i>XMTS510_xxx_<mode>.exe</i>
MDA board	
MDA100	<i>XMDA100_xxx_<mode>.exe</i>
MDA300	<i>XMDA300_xxx_<mode>.exe</i>
MDA320	<i>XMDA300_xxx_<mode>.exe</i>
MDA500	<i>XMDA500_xxx_<mode>.exe</i>
Base Station (common to all boards)	
<i>XMeshBase_Dot_xxx_<mode>.exe</i>	

xxx = 315, 433, 915 or 2400. <mode> = hp or lp. hp = high power mesh networking. lp = low-power mesh networking via low-power listening and time synchronized data transmissions.

10.1 Testing a Sensor or Data Acquisition Board

To test a sensor or data acquisition board, the appropriate test or demo firmware needs to be programmed into a Mote. The sensor or data acquisition board would then be attached to the Mote. Finally, the data from it could then be displayed on MoteView GUI. All the details for doing this are in the *MoteView User's Manual*.

11 Appendix B. Warranty and Support Information

11.1 Customer Service

As a Crossbow Technology customer you have access to product support services, which include:

- Single-point return service
- Web-based support service
- Same day troubleshooting assistance
- Worldwide Crossbow representation
- Onsite and factory training available
- Preventative maintenance and repair programs
- Installation assistance available

11.2 Contact Directory

United States: Phone: 1-408-965-3300 (8 AM to 5 PM PST)

Fax: 1-408-324-4840 (24 hours)

Email: techsupport@xbow.com

Non-U.S.: refer to website www.xbow.com

11.3 Return Procedure

11.3.1 Authorization

Before returning any equipment, please contact Crossbow to obtain a Returned Material Authorization number (RMA).

Be ready to provide the following information when requesting a RMA:

- Name
- Address
- Telephone, Fax, Email
- Equipment Model Number
- Equipment Serial Number
- Installation Date
- Failure Date
- Fault Description

11.3.2 Identification and Protection

If the equipment is to be shipped to Crossbow for service or repair, please attach a tag TO THE EQUIPMENT, as well as the shipping container(s), identifying the owner. Also indicate the service or repair required, the problems encountered and other information considered valuable to the service facility such as the list of information provided to request the RMA number.

Place the equipment in the original shipping container(s), making sure there is adequate packing around all sides of the equipment. If the original shipping containers were discarded, use heavy boxes with adequate padding and protection.

11.3.3 Sealing the Container

Seal the shipping container(s) with heavy tape or metal bands strong enough to handle the weight of the equipment and the container.

11.3.4 Marking

Please write the words, "**FRAGILE, DELICATE INSTRUMENT**" in several places on the outside of the shipping container(s). In all correspondence, please refer to the equipment by the model number, the serial number, and the RMA number.

11.3.5 Return Shipping Address

Use the following address for all returned products:

Crossbow Technology, Inc.
4145 N. First Street
San Jose, CA 95134
Attn: RMA Number (XXXXXX)

11.4 Warranty

The Crossbow product warranty is one year from date of shipment.



Crossbow Technology, Inc.

4145 N. First Street

San Jose, CA 95134

Phone: 408.965.3300

Fax: 408.324.4840