

ELEC 391 - Electrical Engineering Design Studio II

Spectrum Analyzers: Sweep and Bandwidth Considerations

Introduction to project management. Problem definition. Design principles and practices. Implementation techniques including circuit design, software design, solid modeling, PCBs, assembling, and packaging. Testing and evaluation. Effective presentations. Pre-requisite: Two of EECE 352, EECE 356, EECE 359, EECE 360, EECE 364, EECE 373. [2-6-0]

ELEC 391 - Electrical Engineering Design Studio II (Summer 2017)

Prof. David G. Michelson

- During this lecture, the instructor will bring up many points and details not given on these slides. Accordingly, it is expected that the student will annotate these notes during the lecture.
- The lecture only introduces the subject matter. Students must complete the reading assignments and problems if they are to master the material.

Introduction

- In a previous lecture, we focused on the basic function and operation of swept-tuned spectrum analyzers.
- Here, we consider the effect of the resolution bandwidth (RB) and sweep time (ST) settings on spectrum analyzer accuracy.
- If the RB is too wide, the spectrum analyzer will not be able to distinguish closely spaced signals and will admit too much noise into the system.
- If the RB is too narrow, the spectrum analyzer will not display accurate results unless the resolution bandwidth filter is given sufficient time to charge up.
- Here, we determine how sweep time (ST), span (SP), resolution bandwidth (RB), and video bandwidth (VB) are coupled.

Objectives

Upon completion of this lecture, ELEC 391 students shall be able to:

- Explain the significance of over and undersampling on spectral estimation.
- Explain how sweep time (ST), span (SP), resolution bandwidth (RB), and video bandwidth (VB) are coupled.
- Predict how changing the resolution bandwidth will affect the noise floor or displayed average noise level (DANL).
- Predict how the sweep time should be adjusted if the resolution bandwidth is altered.

Outline

1. Basic Spectrum Analyzer Operation
2. Optimizing Spectrum Analyzer Settings
3. Summary of Results

1. Basic Spectrum Analyzer Operation

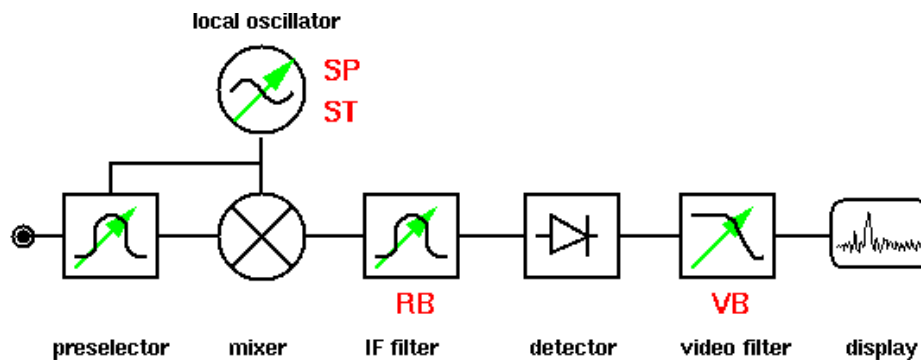

- The above figure shows the essential components required to illustrate the function and operation of a minimal swept-tuned spectrum analyzer.

- The preselector, if it is present, is a broadband tunable filter that tracks the local oscillator and limits the range of RF signals that can reach the mixer.
- The preselector bandwidth does not enter into sweep time calculations.
- The *local oscillator* sweeps between the start and stop frequencies over a specified *span*, SP , in a certain *sweep time*, ST .
- The ability of the spectrum analyzer to resolve two closely spaced signals is controlled by the intermediate frequency filter, which has an adjustable resolution bandwidth, RB .
- The variance of the noise, but not the mean noise level, can be reduced by the video filter, which has an adjustable video bandwidth, VB .
- While the sweep time can be specified by the user, it is usually calculated by the spectrum analyzer in the manner described in this lecture.

- In any case, one should be aware of whether the RB is less or greater than SP/N_{samples} .
- If $RB < SP/N_{\text{samples}}$, then the spectrum is undersampled. Many spectral features, some possibly significant, may not be visible.

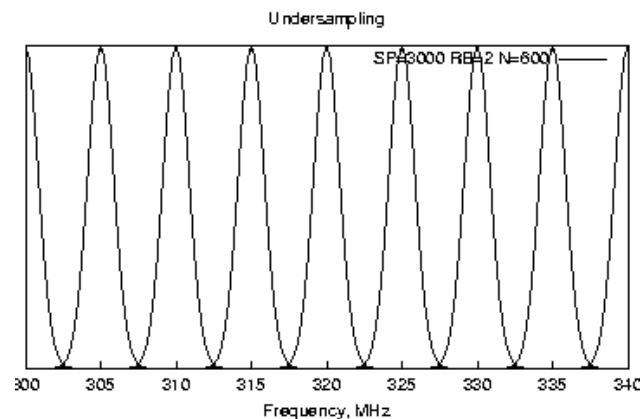

- If $RB > SP/N_{\text{samples}}$, then the spectrum is oversampled. Many spectral features, some possibly significant, will contribute to more than one sample.

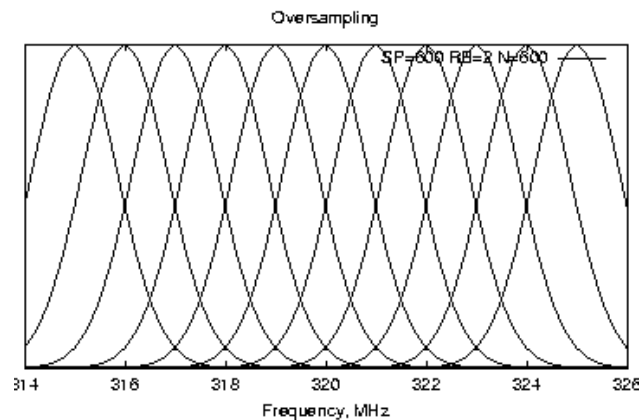

2. Optimizing Spectrum Analyzer Settings

- The spectrum analyzer parameters of sweep time (ST), span (SP), resolution bandwidth (RB) and video bandwidth (VB) are coupled. The form of the coupling depends upon the criteria are to be optimized.
- The price of higher RB is higher noise in the spectrum.
- The thermal noise contribution is given by

$$N = kTB$$

where k = Boltzmann's constant, $1.38 \times 10^{-23} \text{ J/K}$, T is temperature (K), and B is the (noise equivalent) bandwidth.

- Other sources of noise may increase this minimum noise floor. This can be accounted for by replacing T by a larger, but fictitious, T_{sys} .

Minimum Sweep Time

- When baseline noise is not an important consideration, one generally wants to minimize the sweep time.
- In this manner, the chances of missing an important transient event are reduced.
- Consider the time that the spectrum analyzer spends in each resolution element,

$$dt_{RB} = \frac{RB}{df/dt} = \frac{RB}{SP/ST} . \quad (1)$$

- We'll consider two cases: without and with video smoothing.

2.1 Without Video Smoothing

- The time which the spectrum analyzer spends in the passband must be consistent with the RB , *i.e.*, the filter must have time to charge up.
- If the passband characteristic is Gaussian,

$$H(f) = \exp\left(-\pi \frac{f^2}{\sigma^2}\right) \quad (2)$$

where f is the frequency relative to the band center and σ is a measure of the width.

- In that case, its inverse Fourier transform, the impulse response of the filter, is

$$h(t) = \sigma \exp(-\pi\sigma^2 t^2) . \quad (3)$$

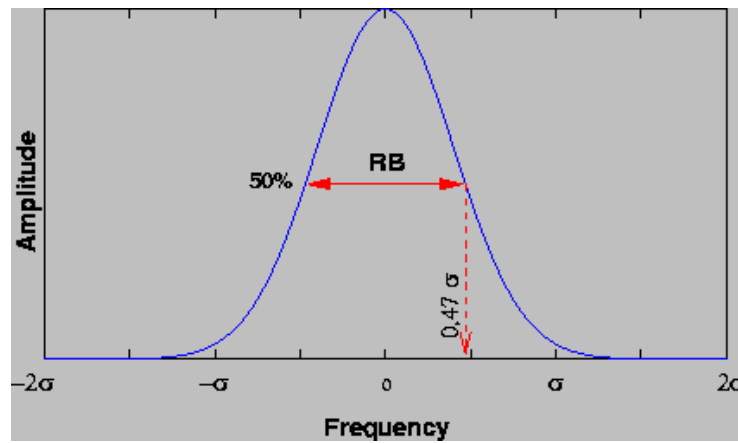

Figure 1: The Resolution Bandwidth (RB) is defined as the width at which the filter response falls to 50% of its maximum.

- The RB is related to σ through eqn. 2 by noting that

$$\begin{aligned} \frac{1}{2} &= \exp\left(-\pi \frac{(RB/2)^2}{\sigma^2}\right) \\ \sigma &= \frac{1}{2} \sqrt{\frac{\pi}{\ln 2}} RB \\ &= 1.0645 RB \end{aligned}$$

- The time it takes for the filter response to rise from $1/x$ of its maximum and then fall again to $1/x$ is given by $2t_{1/x}$ where (see eqn. 3):

$$\begin{aligned} \frac{\sigma}{x} &= \sigma \exp(-\pi\sigma^2 t_{1/x}^2) \\ t_{1/x} &= \sqrt{\frac{\ln x}{\pi}} \frac{1}{\sigma} \\ &= \frac{2\sqrt{\ln x \ln 2}}{\pi} \frac{1}{RB} \\ &= \frac{0.53\sqrt{\ln x}}{RB} \end{aligned}$$

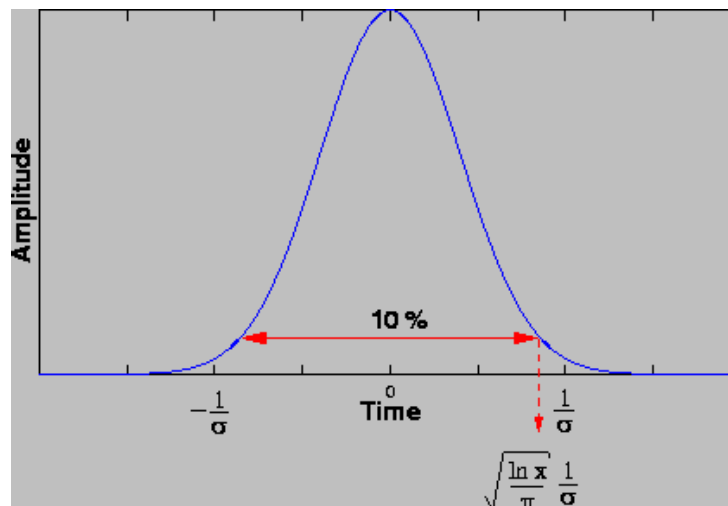

Figure 2: In this illustration, the time interval shown is sufficient for the filter to rise from 0.1 of its maximum response, and then fall back to 0.1. (This corresponds to $x = 10$ on slide 16.)

- For example, to give the filter time to rise from 1% of its maximum response and then to discharge to 1%, $x = 100$, and $2t_{1/100} = 2.27/RB$.
- Agilent, for example, uses a factor of 2.5, so that eqn. 1 leads to

$$\frac{2.5}{RB} = \frac{RB}{SP/ST}$$

so

$$ST = 2.5 \frac{SP}{RB^2}. \quad (4)$$

- This requires that the bandwidth of the video filter is wide enough to pass the fastest signal fluctuations generated by the sweep.
- Using the same criterion as for the IF filter,

$$\begin{aligned} VB &\geq \frac{2.5}{dt_{\text{video}}} = \frac{2.5}{\frac{RB}{df/dt}} = \frac{2.5}{\frac{RB}{SP} ST} = \frac{2.5}{\frac{RB}{SP} 2.5 \frac{SP}{RB^2}} \\ &\geq RB \end{aligned}$$

- This is the default mode for most spectrum analyzers, *i.e.*, when VBW and ST are set to AUTO.

2.2 With Video Smoothing

- When VBW is set to MAN and $VB \leq RB$, extra time must be allowed for the video filter to settle.
- Thus the sweep time equation becomes

$$\frac{2.5}{VB} = \frac{RB}{SP/ST}$$

so

$$ST = 2.5 \frac{SP}{RB \cdot VB} \quad (5)$$

- Video smoothing has the effect of reducing the noise in the baseline by increasing the time in each resolution element by a factor of RB/VB .

- In addition to separately controlling both RB and VB , most spectrum analyzers allow the RB/VB ratio to be set so that it is kept fixed as RB is changed.

3. Summary of Results

- If ST is not set to MAN, most spectrum analyzers will automatically calculate the minimum sweeptime according to

$$ST = \begin{cases} 2.5 \frac{SP}{RB^2} & , \quad VB \geq RB \\ 2.5 \frac{SP}{RB^2} \frac{RB}{VB} & , \quad VB \leq RB \end{cases} \quad (6)$$

- If the sweep time is set manually to less than this value, the filters will not respond correctly and the amplitude of the spectrum analyzer will not be correctly calibrated. The UNCAL symbol will appear on the display.
- In general, doubling the resolution bandwidth will double the noise floor (in linear units) or increase it by 3 dB (in logarithmic units).
- In general, doubling the resolution bandwidth will reduce the required sweeptime by a factor of four.

Mode	Span	RBW	VBW	ST	Effective Int. Time	Notes
default	specified	specified	AUTO	AUTO	2.5/RB	VB=RB; fastest possible ST; good for narrow signals
optional	specified	specified	MAN	AUTO	2.5/VB	reduces noise power by $\sqrt{VB/RB}$
optional	specified	specified	MAN	MAN	2.5/VB	does not minimize noise effectively if $ST > ST_{min}$; amplitude is uncalibrated if $ST < ST_{min}$

References

- [1] T. Kuiper, "Spectrum Analyzer Sweep and Bandwidth Considerations," JPL, 2000.
- [2] "Spectrum Analyzer Basics," AN-150, Agilent Technologies.