EECE488: Analog CMOS Integrated Circuit Design

Set 5

Current Mirrors

Shahriar Mirabbasi

Department of Electrical and Computer Engineering

University of British Columbia

shahriar@ece.ubc.ca

Applications of Current Sources

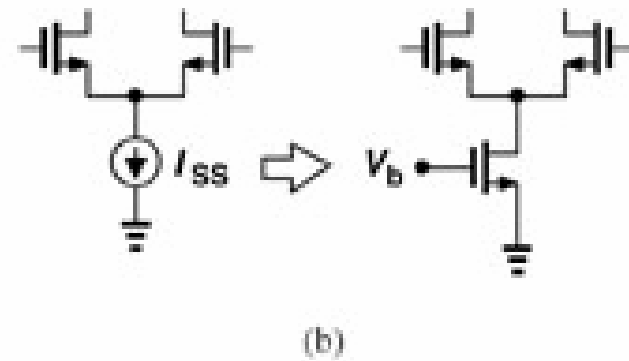
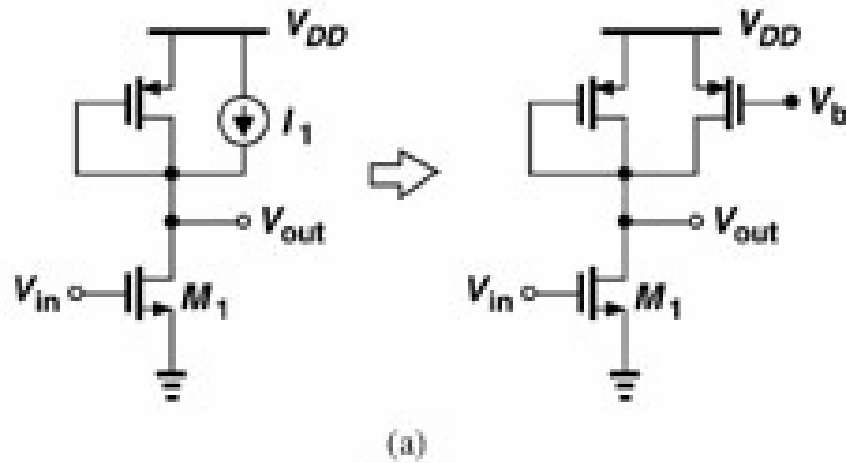

Simple Resistive Biasing for Current Source

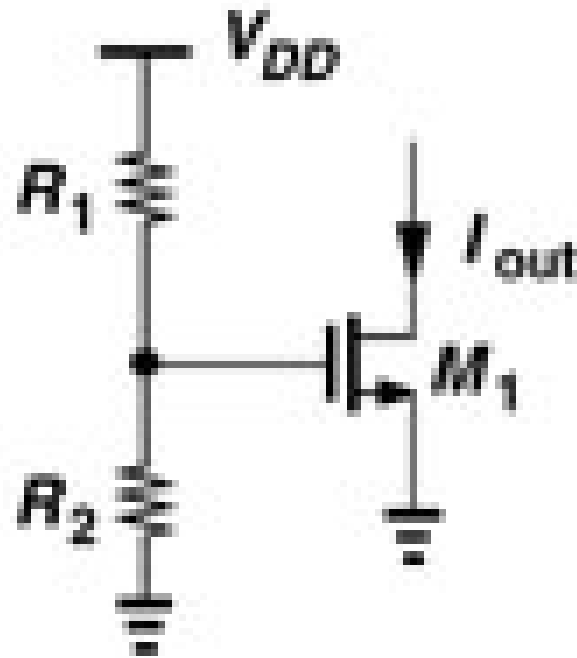

$$I_{OUT} \approx \frac{\mu_n C_{ox}}{2} \frac{W}{L} \left(\frac{R_2}{R_2 + R_1} V_{DD} - V_{TH} \right)^2$$

Problems

- Output current depends on:
 - Supply
 - Process
 - Temperature
- What if the bias voltage is independent of supply voltage?
- Is there a way of generating reliable currents?

Basic Idea

Typically we assume that one precisely defined current source is available and other current sources copy their current from this precise source.

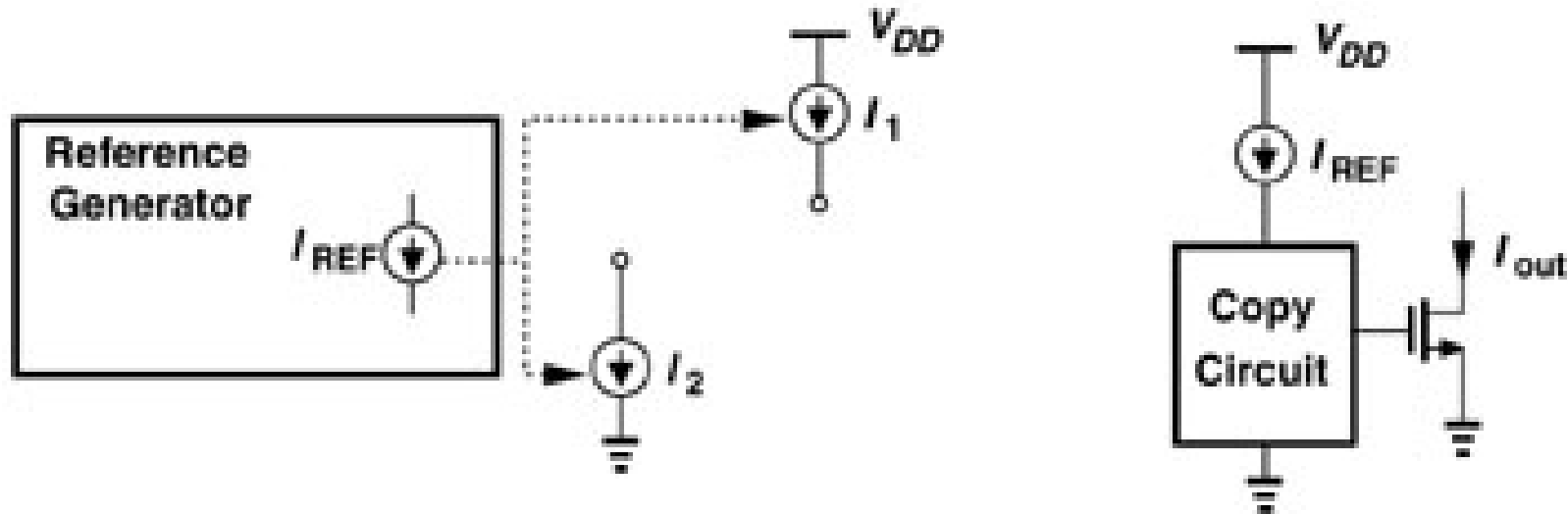

I_{out} is a function of gate-source voltage

Basic Idea

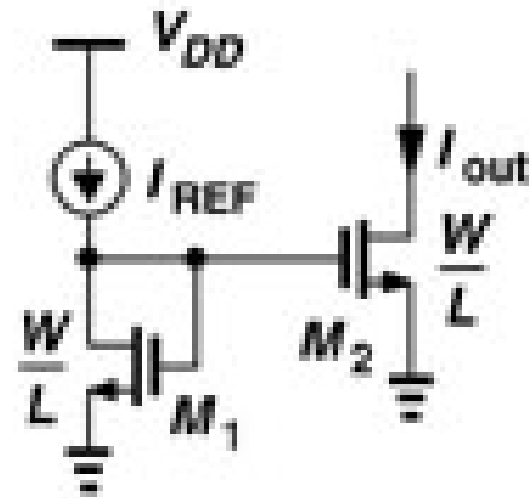
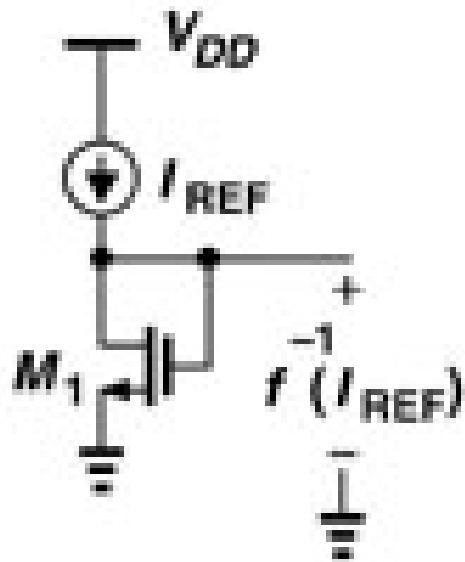

This structure is called current mirror

Question

- What happens if the two transistors in the basic current mirror have different sizes?

Example

Assuming all the transistors are in saturation region, find I_{out} :

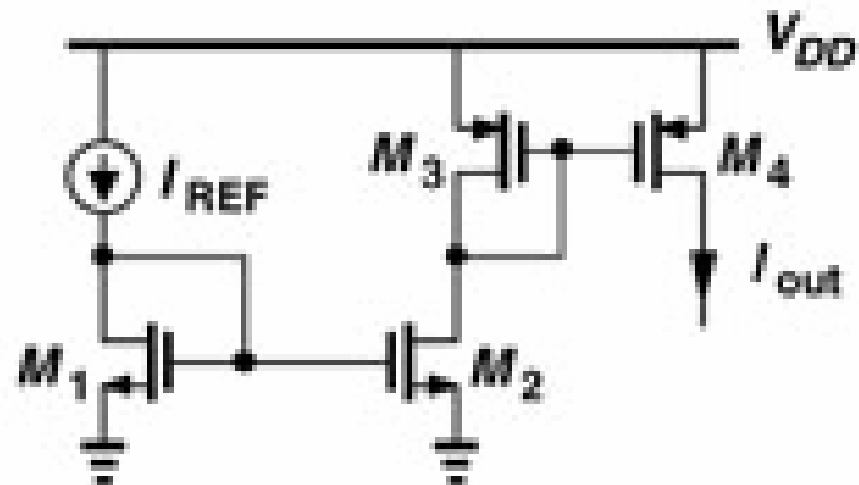

Current Mirrors: Amplifier Bias Example

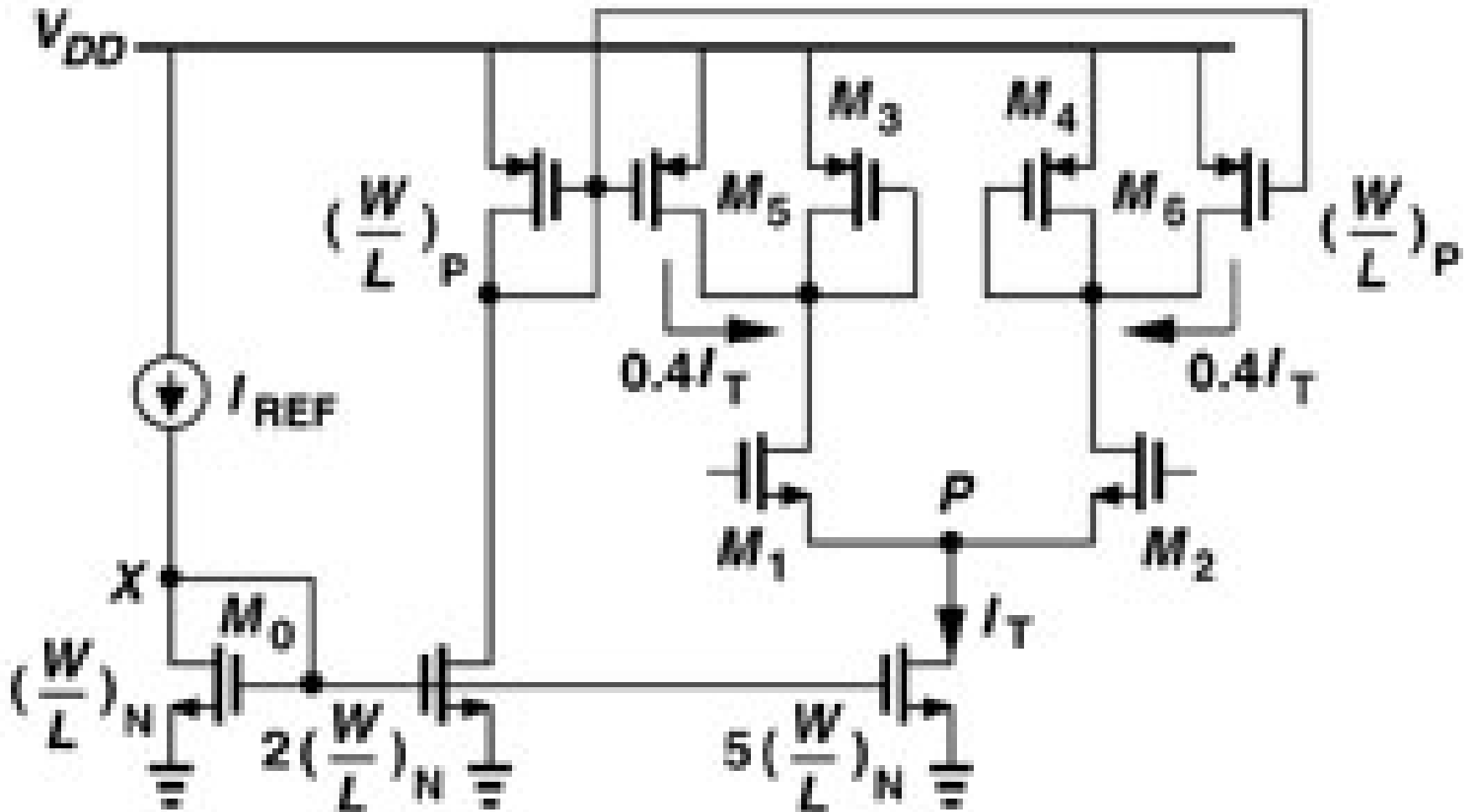

Board Notes

Current Mirrors: Signal Amplification Example

- Find the small signal voltage gain of the following circuit.

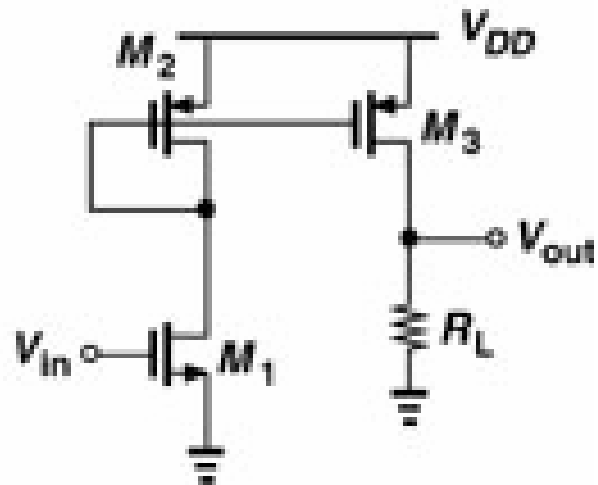

Effect of Channel Length Modulation

Cascode Current Mirror

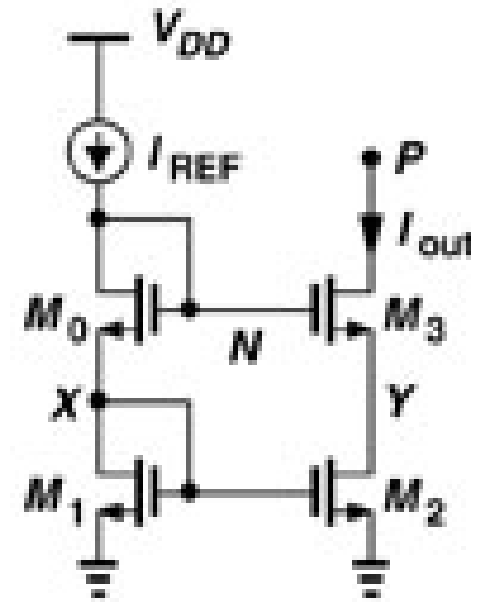
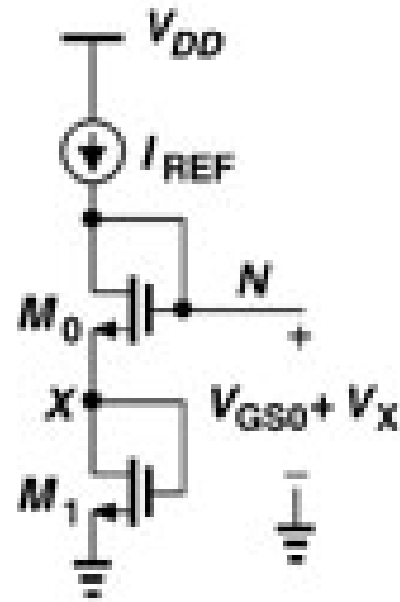
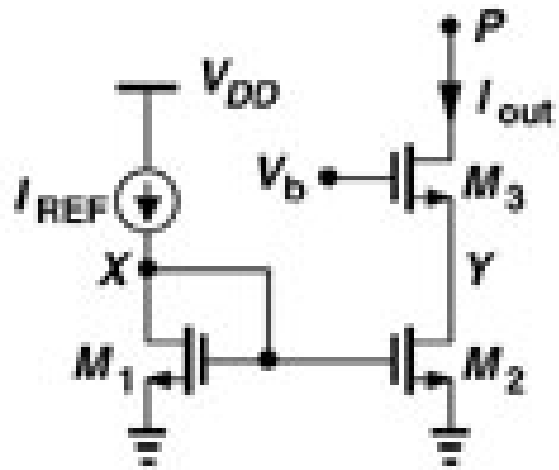

Board Notes

Cascode Current Mirror

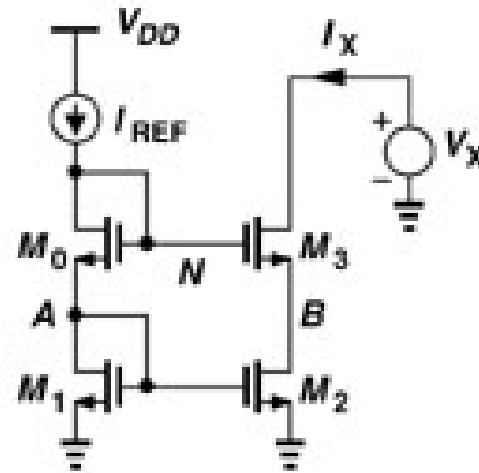

(a)

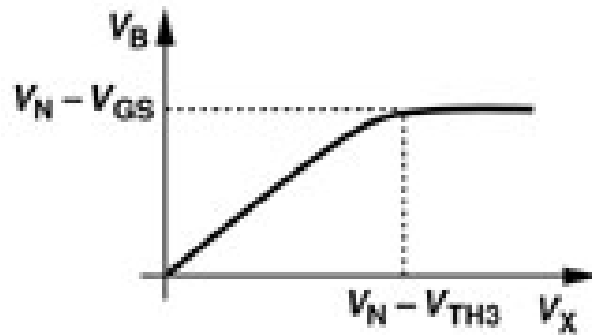

(b)

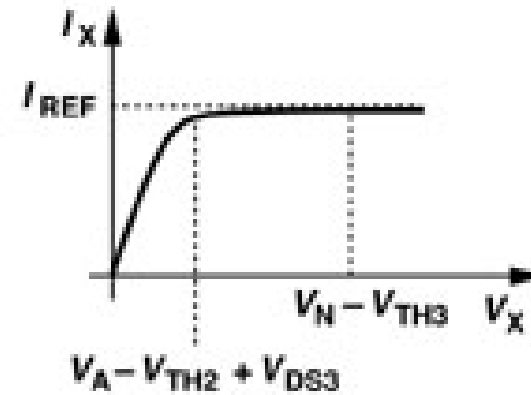

(c)

Cascode Current Mirror

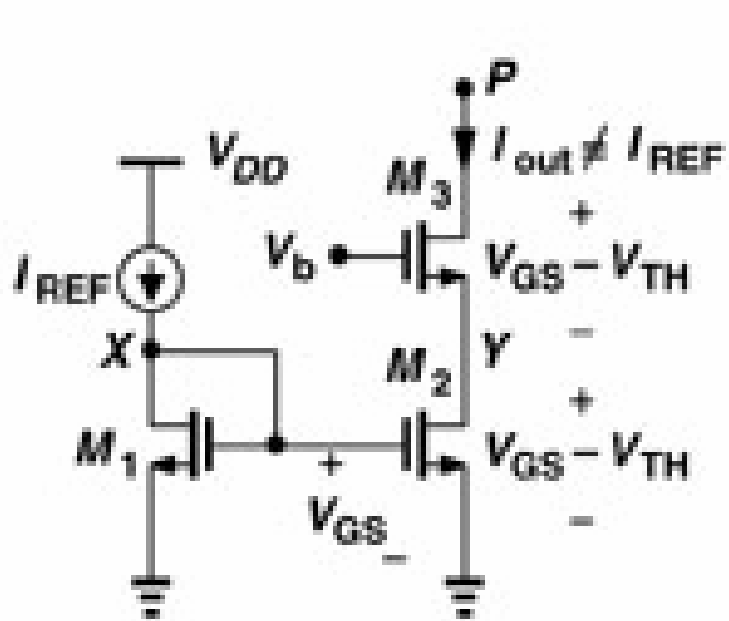

(a)

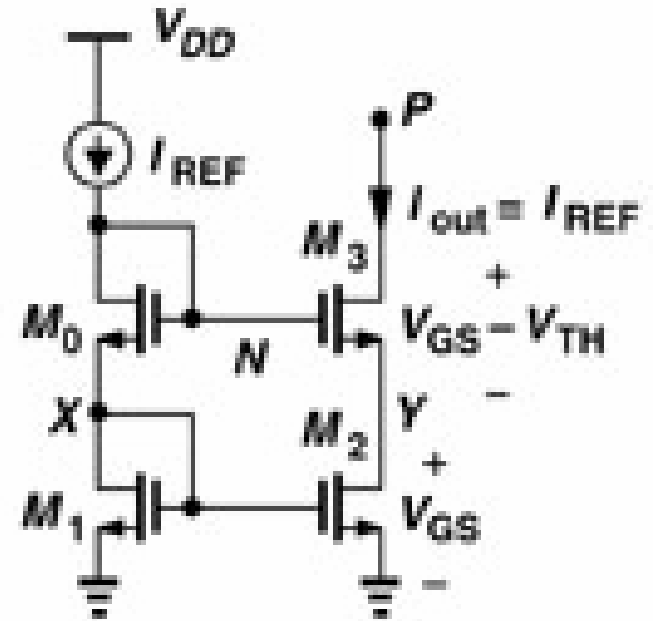

(b)

Cascode Current Mirror

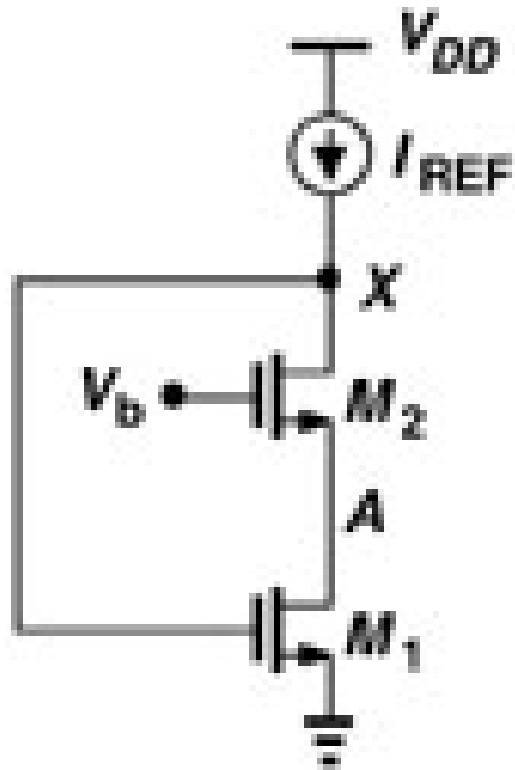

(a)

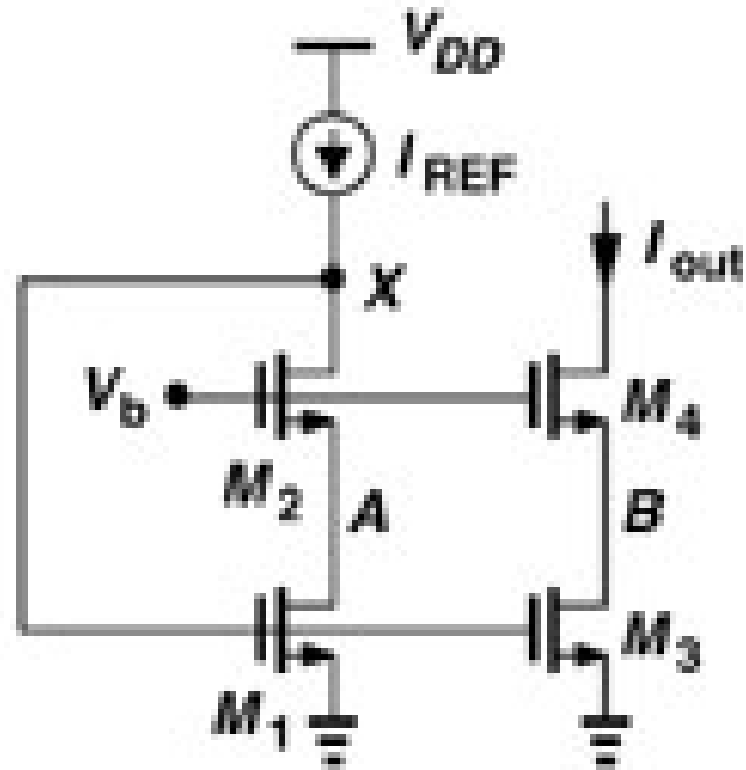

(b)

Board Notes

Cascode Current Mirror Biasing

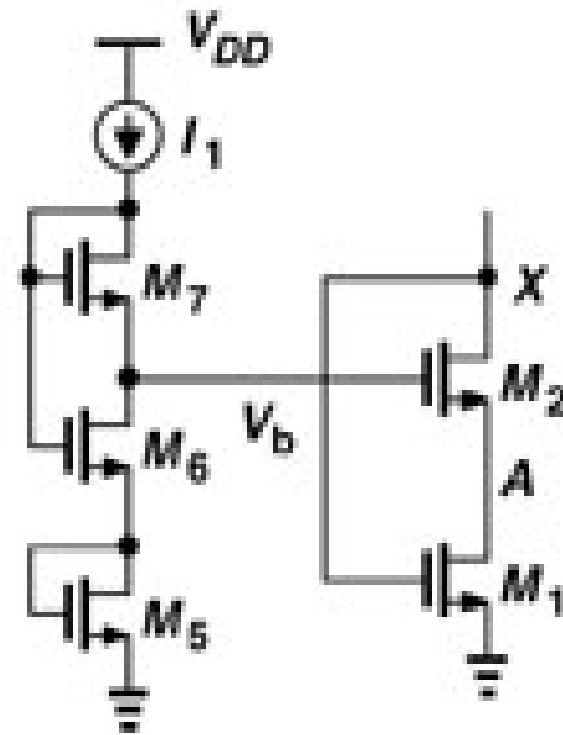
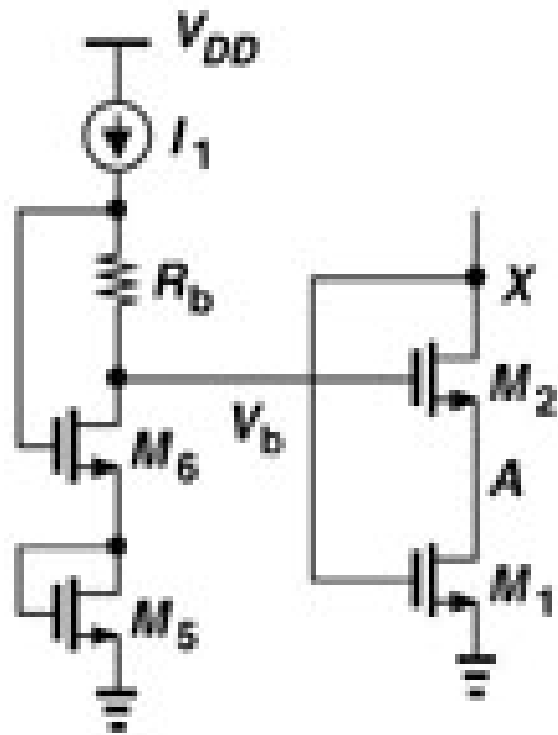

Cascode Current Mirror Biasing

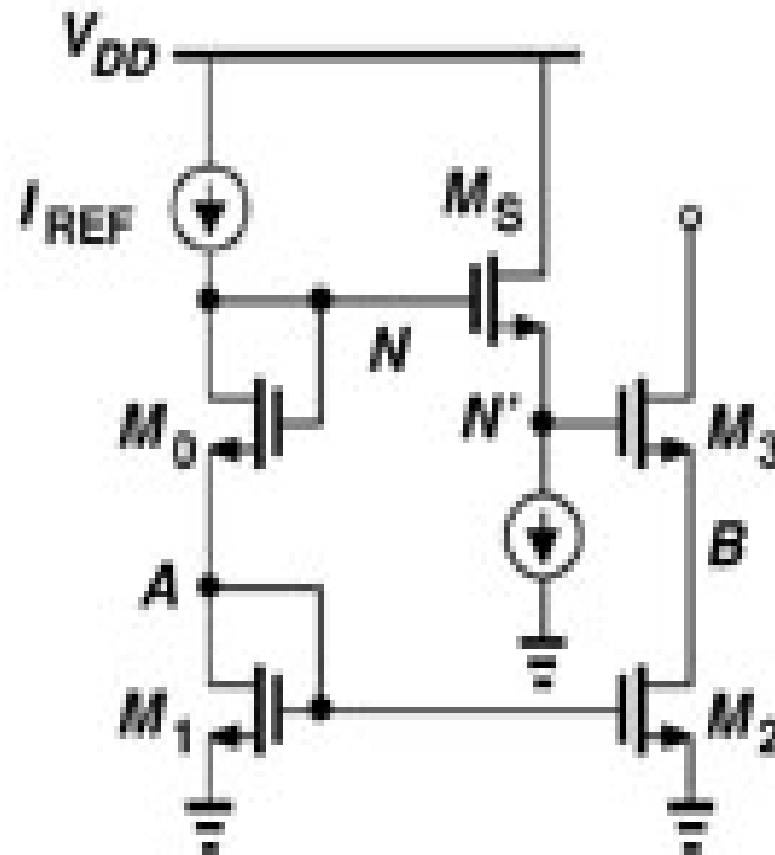

Current Mirror Biasing

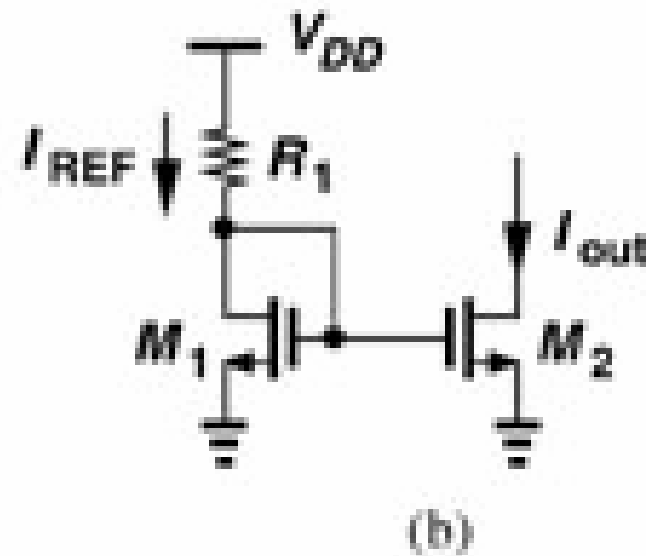
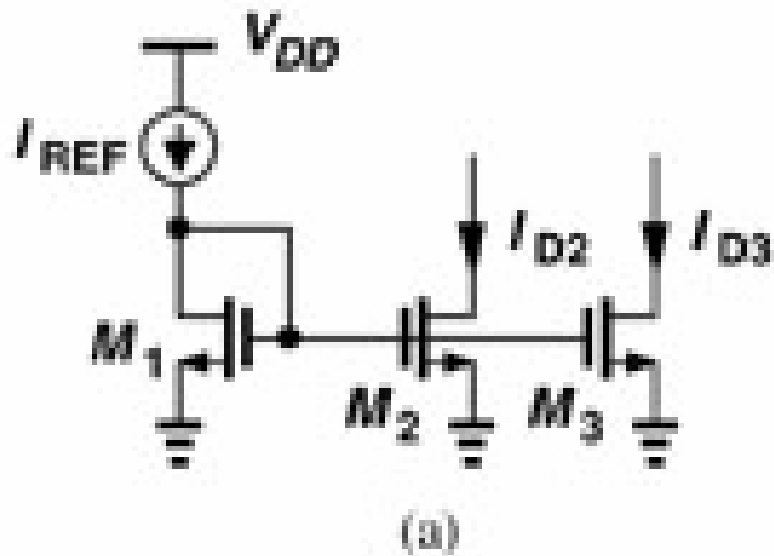

Basic Circuit to Generate Supply Independent Current

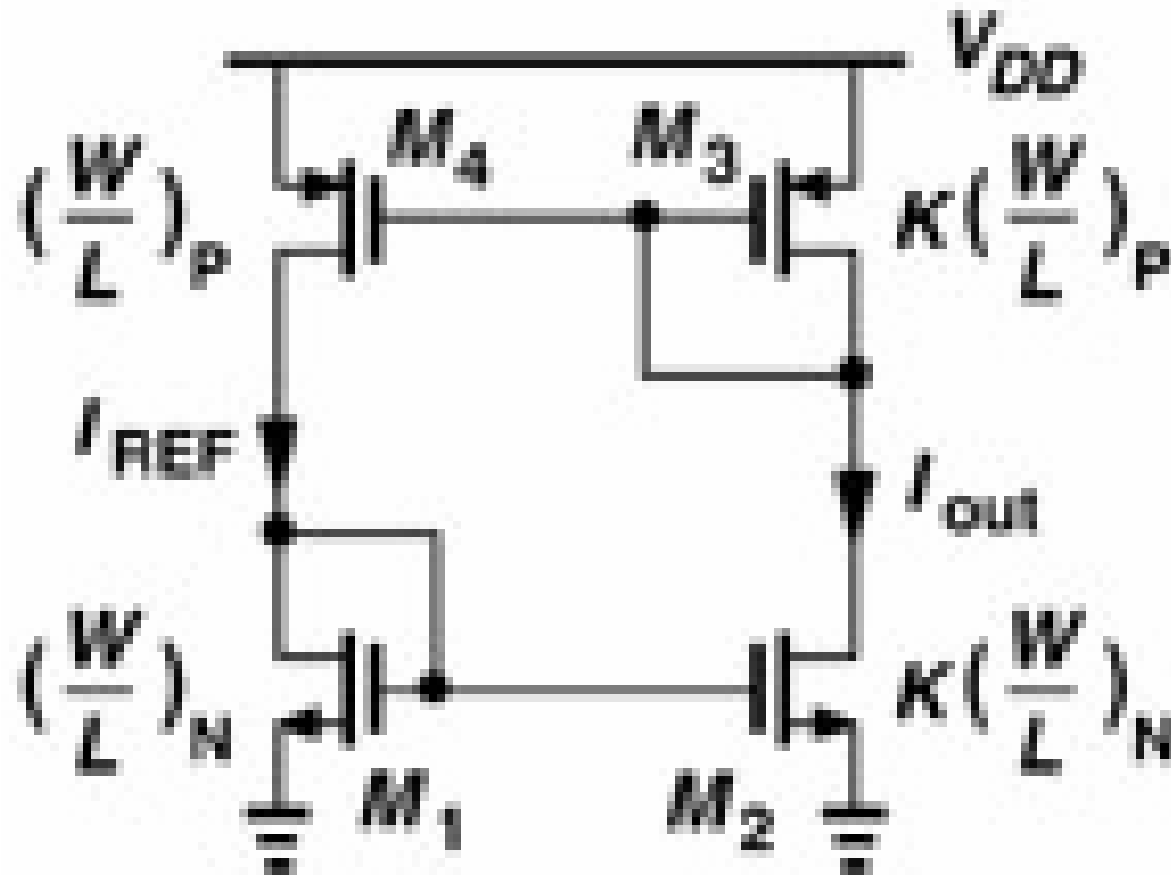

Supply Independent Current

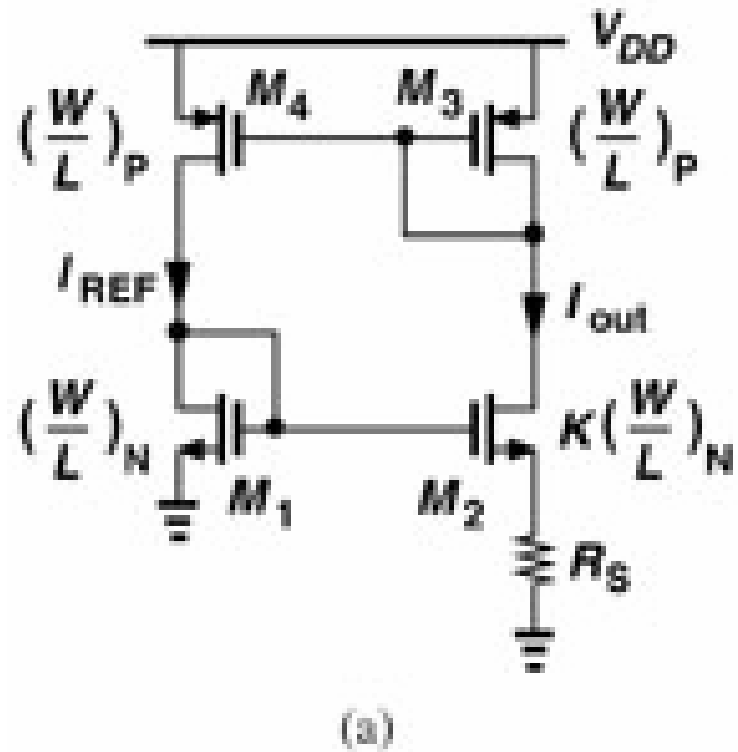

Board Notes

Supply Independent Current

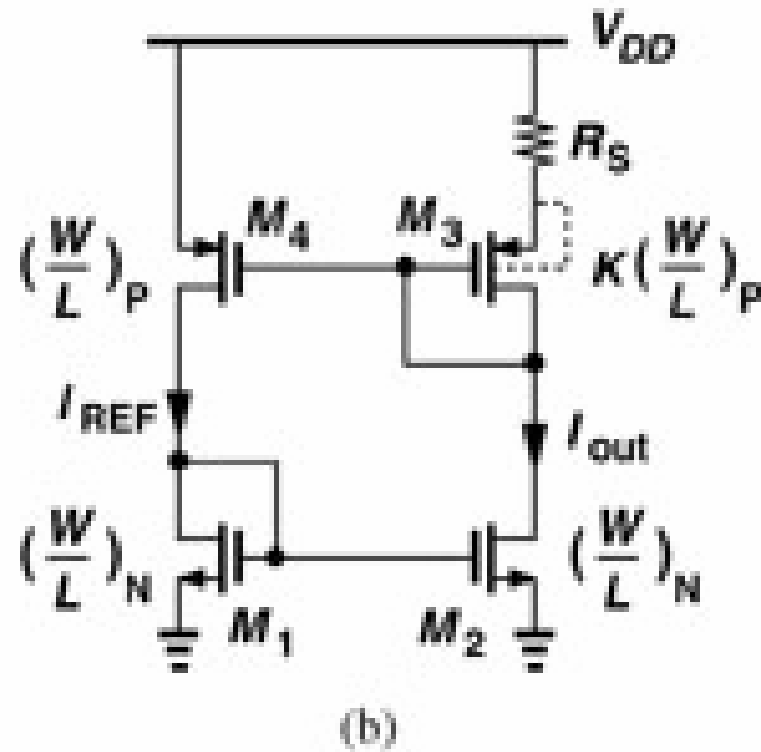

Start-up Problem

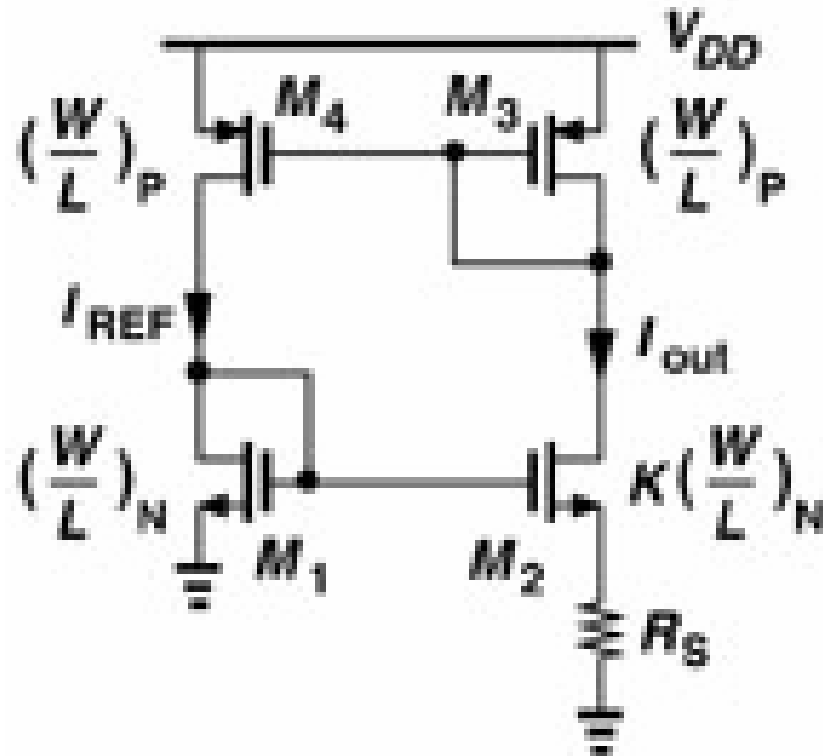

(3)

Start-up Problem

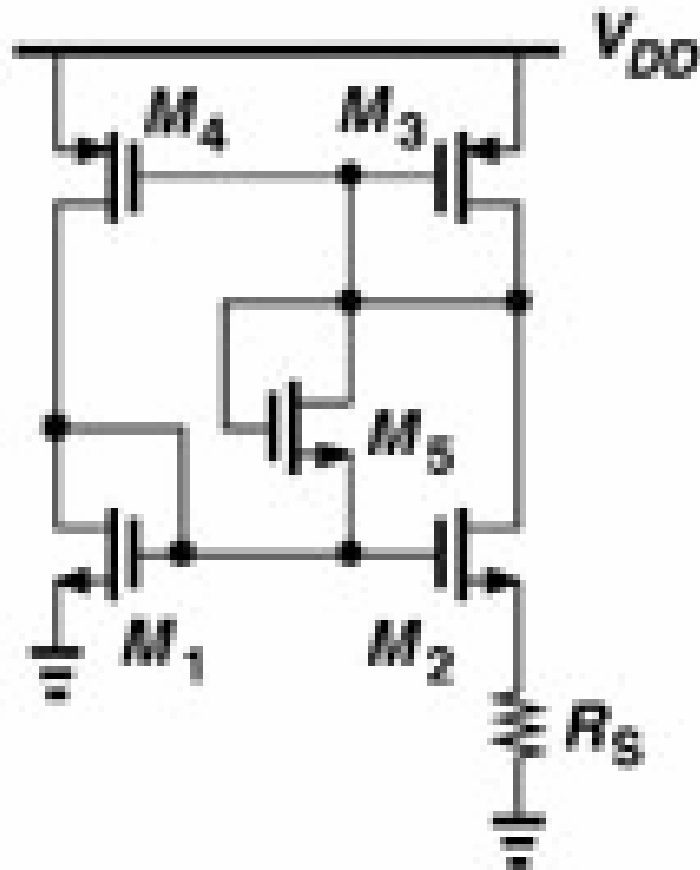

$$V_{TH1} + V_{TH5} + |V_{TH3}| < V_{DD} \quad \text{and} \quad V_{GS1} + V_{TH5} + |V_{GS3}| > V_{DD}$$

Board Notes

Active Current Mirrors

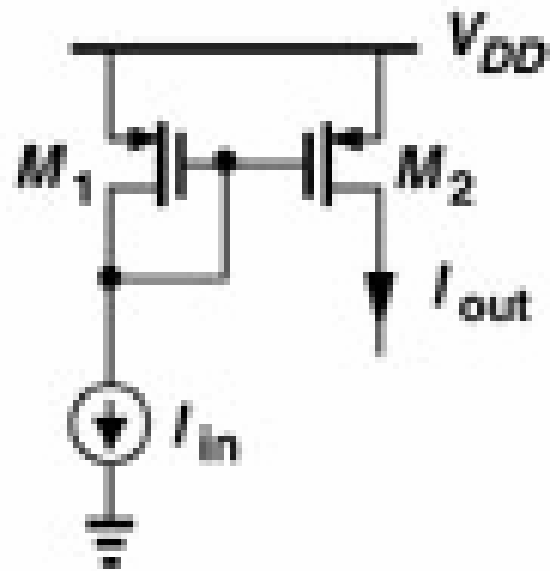

Active Current Mirrors in Differential to Single-Ended Amplifiers

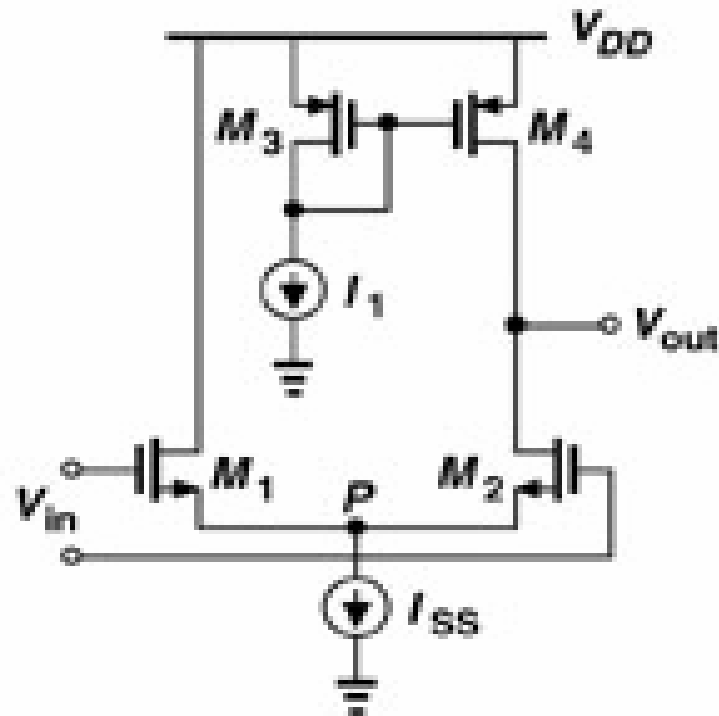

Differential to Single-Ended Amplifiers

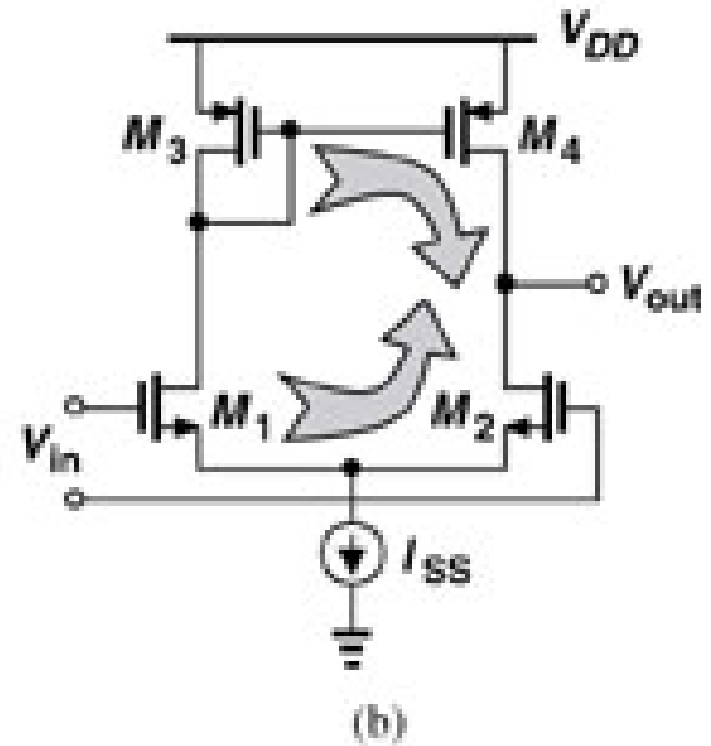
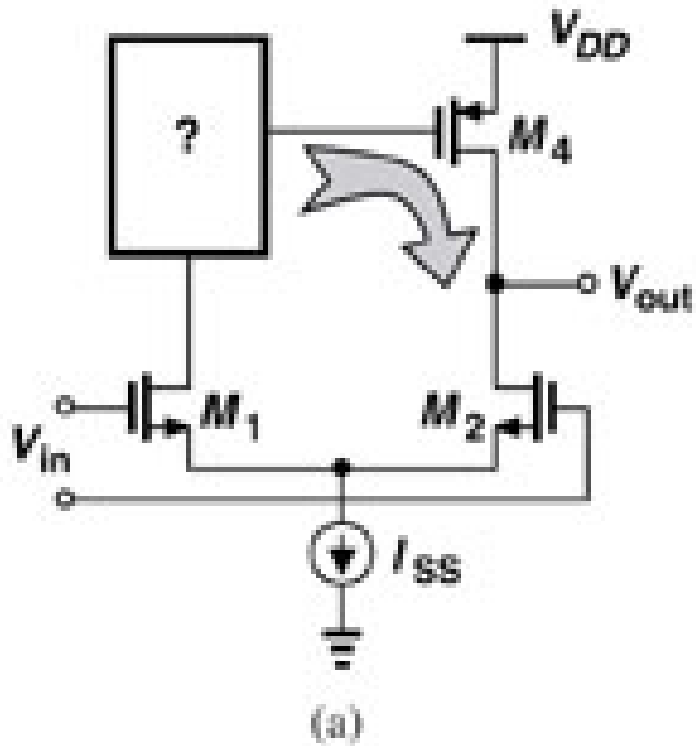

Calculation of G_m

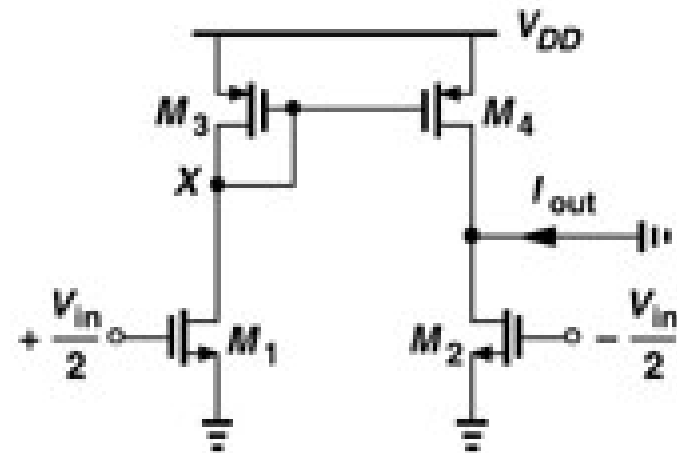
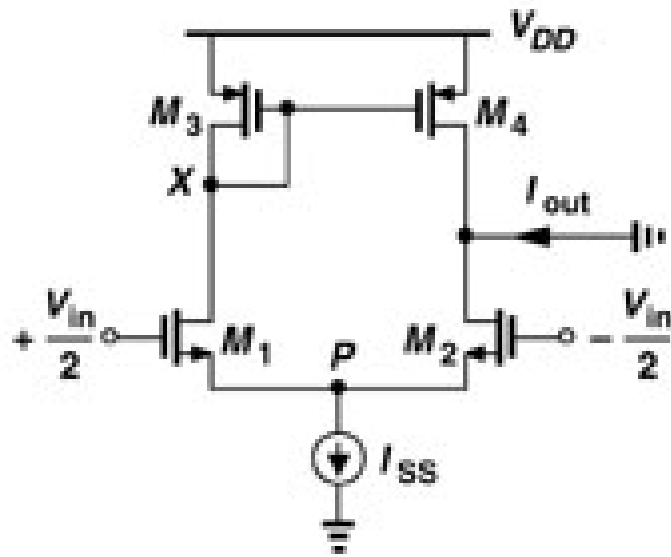

$$I_{D1} = I_{D3} = I_{D4} = g_{m1,2} V_{in} / 2 \quad I_{D2} = -g_{m1,2} V_{in} / 2$$

$$I_{out} = I_{D2} - I_{D4} = -g_{m1,2} V_{in} \Rightarrow G_m = g_{m1,2}$$

Common Mode Characteristics

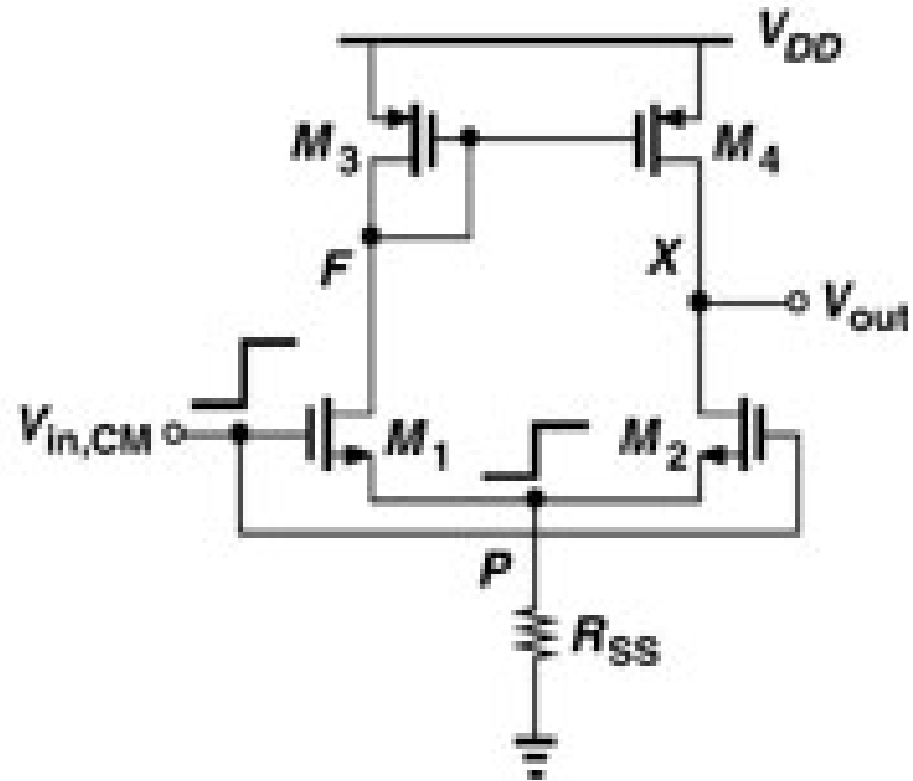

$$A_{CM} = \frac{\Delta V_{out}}{\Delta V_{in,CM}}$$

Common Mode

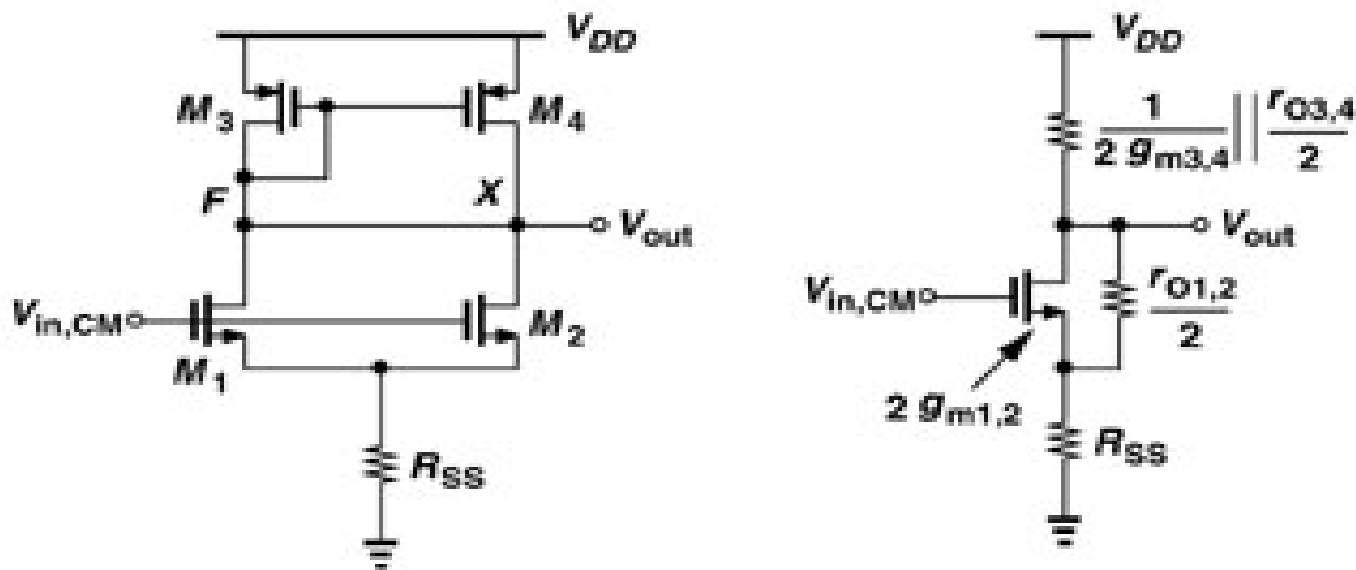

$$A_{CM} \approx \frac{-\frac{1}{2g_{m3,4}} \parallel \frac{r_{o3,4}}{2}}{\frac{1}{2g_{m1,2}} + R_{SS}} = \frac{-1}{1 + 2g_{m1,2}R_{SS}} \frac{g_{m1,2}}{g_{m3,4}}$$

Common Mode

$$\begin{aligned} CMRR &= \left| \frac{A_{DM}}{A_{CM}} \right| \\ &= g_{m1,2} (r_{o1,2} \parallel r_{o3,4}) \frac{g_{m3,4} (1 + 2g_{m1,2} R_{SS})}{g_{m1,2}} \\ &= g_{m3,4} (r_{o1,2} \parallel r_{o3,4}) (1 + 2g_{m1,2} R_{SS}) \end{aligned}$$